



west virginia department of environmental protection

Office of Oil and Gas
601 57th Street, S.E.
Charleston, WV 25304
(304) 926-0450
fax: (304) 926-0452

Austin Caperton, Cabinet Secretary
www.dep.wv.gov

Tuesday, November 5, 2019
WELL WORK PERMIT
Horizontal 6A / New Drill

TUG HILL OPERATING, LLC
380 SOUTHPOINTE BLVD

CANONSBURG, PA 15317

Re: Permit approval for GOUDY 1S-17HU
47-051-02196-00-00

This well work permit is evidence of permission granted to perform the specified well work at the location described on the attached pages and located on the attached plat, subject to the provisions of Chapter 22 of the West Virginia Code of 1931, as amended, and all rules and regulations promulgated thereunder, and to any additional specific conditions and provisions outlined in the pages attached hereto. Notification shall be given by the operator to the Oil and Gas Inspector at least 24 hours prior to the construction of roads, locations, and/or pits for any permitted work. In addition, the well operator shall notify the same inspector 24 hours before any actual well work is commenced and prior to running and cementing casing. Spills or emergency discharges must be promptly reported by the operator to 1-800-642-3074 and to the Oil and Gas Inspector.

Please be advised that form WR-35, Well Operators Report of Well Work is to be submitted to this office within 90 days of completion of permitted well work, as should form WR-34 Discharge Monitoring Report within 30 days of discharge of pits, if applicable. Failure to abide by all statutory and regulatory provisions governing all duties and operations hereunder may result in suspension or revocation of this permit and, in addition, may result in civil and/or criminal penalties being imposed upon the operators.

Per 35 CSR 4-5.2.g this permit will expire in two (2) years from the issue date unless permitted well work is commenced. If there are any questions, please feel free to contact me at (304) 926- 0450.

James A. Martin
Chief

Operator's Well Number: GOUDY 1S-17HU
Farm Name: TH EXPLORATION III, LLC.
U.S. WELL NUMBER: 47-051-02196-00-00
Horizontal 6A New Drill
Date Issued: 11/5/2019

PERMIT CONDITIONS

West Virginia Code § 22-6A-8(d) allows the Office of Oil and Gas to place specific conditions upon this permit. Permit conditions have the same effect as law. Failure to adhere to the specified permit conditions may result in enforcement action.

CONDITIONS

1. This proposed activity may require permit coverage from the United States Army Corps of Engineers (USACE). Through this permit, you are hereby being advised to consult with USACE regarding this proposed activity.
2. If the operator encounters an unanticipated void, or an anticipated void at an unanticipated depth, the operator shall notify the inspector within 24 hours. Modifications to the casing program may be necessary to comply with W. Va. Code § 22-6A-5a (12), which requires drilling to a minimum depth of thirty feet below the bottom of the void, and installing a minimum of twenty (20) feet of casing. Under no circumstance should the operator drill more than one hundred (100) feet below the bottom of the void or install less than twenty (20) feet of casing below the bottom of the void.
3. When compacting fills, each lift before compaction shall not be more than 12 inches in height, and the moisture content of the fill material shall be within limits as determined by the Standard Proctor Density test of the actual soils used in specific engineered fill, ASTM D698, Standard Test Method for Laboratory Compaction Characteristics of Soil Using Standard Effort, to achieve 95 % compaction of the optimum density. Each lift shall be tested for compaction, with a minimum of two tests per lift per acre of fill. All test results shall be maintained on site and available for review.
4. Operator shall install signage per § 22-6A-8g (6) (B) at all source water locations included in their approved water management plan within 24 hours of water management plan activation.
5. Oil and gas water supply wells will be registered with the Office of Oil and Gas and all such wells will be constructed and plugged in accordance with the standards of the Bureau for Public Health set forth in its Legislative rule entitled *Water Well Regulations*, 64 C.S.R. 19. Operator is to contact the Bureau of Public Health regarding permit requirements. In lieu of plugging, the operator may transfer the well to the surface owner upon agreement of the parties. All drinking water wells within fifteen hundred feet of the water supply well shall be flow tested by the operator upon request of the drinking well owner prior to operating the water supply well.
6. Pursuant to the requirements pertaining to the sampling of domestic water supply wells/springs the operator shall, no later than thirty (30) days after receipt of analytical data provide a written copy to the Chief and any of the users who may have requested such analyses.
7. 24 hours prior to the initiation of the completion process the operator shall notify the Chief or his designee.
8. During the completion process the operator shall monitor annular pressures and report any anomaly noticed to the chief or his designee immediately.
9. If any explosion or other accident causing loss of life or serious personal injury occurs in or about a well or well work on a well, the well operator or its contractor shall give notice, stating the particulars of the explosion or accident, to the oil and gas inspector and the Chief, within 24 hours of said accident.
10. During the casing and cementing process, in the event cement does not return to the surface, the oil and gas inspector shall be notified within 24 hours.

PERMIT CONDITIONS

11. The operator shall provide to the Office of Oil and Gas the dates of each of the following within 30 days of their occurrence: completion of construction of the well pad, commencement of drilling, cessation of drilling, completion of any other permitted well work, and completion of the well. Such notice shall be provided by sending an email to DEPOOGNotify@wv.gov.



west virginia department of environmental protection

Oil and Gas Conservation Commission
601 57th Street SE, Charleston, WV 25304
304-926-0499 Ext 1274

Barry K. Lay, Chairman
dep.wv.gov

October 2, 2019

Department of Environmental Protection
Office of Oil and Gas
Charleston, WV 25304

RE: Application for Deep Well Permit – API #47-051-02196

COMPANY: Tug Hill Operating, LLC

FARM: TH Exploration III, LLC Goudy 1S-17HU

COUNTY: Marshall DISTRICT: Franklin QUAD: New Martinsville

The deep well review of the application for the above company is Approved to drill to Trenton for Point Pleasant completion.

The applicant has complied with the provision of Chapter 22C-9, of the Code of West Virginia, nineteen hundred and thirty-one (1931), as amended, Oil and Gas Conservation Commission as follows:

1. Comments to Notice of Deviation filed? No
2. Provided a certified copy of duly acknowledged and recorded consent and easement form from all surface owners? Yes
3. Provided a tabulation of all deep wells within one mile of the proposed location, including the API number of all deep wells: **yes; Docket 287-283 Exception Location Hearing
4. Provided a plat showing that the proposed location is a distance of 400 feet from the nearest lease line or unit boundary and showing the following wells drilled to or capable of producing from the objective formation within 3,000 feet of the proposed location.

Sincerely,

A handwritten signature in blue ink that reads "Susan Rose".

Susan Rose
Administrator

STATE OF WEST VIRGINIA
DEPARTMENT OF ENVIRONMENTAL PROTECTION, OFFICE OF OIL AND GAS
WELL WORK PERMIT APPLICATION

1) Well Operator: Tug Hill Operating, LLC

<u>494510851</u>	<u>Marshall</u>	<u>Franklin</u>	<u>Glen Easton 7.5'</u>
------------------	-----------------	-----------------	-------------------------

Operator ID County District Quadrangle

2) Operator's Well Number: Goudy 1S-17HU Well Pad Name: Goudy

3) Farm Name/Surface Owner: TH Exploration III, LLC Public Road Access: Wells Hill Road (Route 22)

4) Elevation, current ground: 1242' Elevation, proposed post-construction: 1242'

5) Well Type (a) Gas Oil _____ Underground Storage _____
Other _____

(b) If Gas Shallow _____ Deep
Horizontal

Ju
6/28/19

6) Existing Pad: Yes or No Yes

7) Proposed Target Formation(s), Depth(s), Anticipated Thickness and Expected Pressure(s):
Point Pleasant is the target formation at a depth of 11,006' - 11,135' thickness of 129' and anticipated pressure of approx. 9500 psi

8) Proposed Total Vertical Depth: 11,285'

9) Formation at Total Vertical Depth: Trenton

10) Proposed Total Measured Depth: 22,545'

11) Proposed Horizontal Leg Length: 11,038.11'

12) Approximate Fresh Water Strata Depths: 70', 862'

13) Method to Determine Fresh Water Depths: Offset well reports or noticeable flow at the flowline or when need to start soaping

14) Approximate Saltwater Depths: 2,167'

15) Approximate Coal Seam Depths: Sewickly Coal - 757' and Pittsburgh Coal - 856'

16) Approximate Depth to Possible Void (coal mine, karst, other): None anticipated

17) Does Proposed well location contain coal seams directly overlying or adjacent to an active mine? Yes _____ No

(a) If Yes, provide Mine Info: Name: _____
Depth: _____
Seam: _____
Owner: _____

18)

CASING AND TUBING PROGRAM

TYPE	<u>Size (in)</u>	<u>New or Used</u>	<u>Grade</u>	<u>Weight per ft. (lb/ft)</u>	<u>FOOTAGE: For Drilling (ft)</u>	<u>INTERVALS: Left in Well (ft)</u>	<u>CEMENT: Fill-up (Cu. Ft.)/CTS</u>
Conductor	30"	NEW	BW	BW	120'	120'	259FT^3(CTS)
Fresh Water	20"	NEW	J55	106.5#	950'	950'	1538ft^3(CTS)
Coal	13 3/8"	NEW	J55	54.5#	2,800'	2,800'	1974ft^3(CTS)
Intermediate	9 5/8"	NEW	J55	47#	9,956'	9,956'	3377ft^3(CTS)
Production	5 1/2"	NEW	P110	23#	22,545'	22,545'	5334ft^3(CTS)
Tubing	2 7/8"	NEW	P110	6.5#		10,672'	
Liners							

JW
6/28/19

TYPE	<u>Size (in)</u>	<u>Wellbore Diameter (in)</u>	<u>Wall Thickness (in)</u>	<u>Burst Pressure (psi)</u>	<u>Anticipated Max. Internal Pressure (psi)</u>	<u>Cement Type</u>	<u>Cement Yield (cu. ft./k)</u>
Conductor	30"	36"	1.0	2,333	1,866	CLASS A	1.2
Fresh Water	20"	26"	.5	2,410	1,928	SEE #24	1.2
Coal	13 3/8"	17 1/2"	.38	2,740	2,192	SEE#24	1.2
Intermediate	9 5/8"	12 1/4"	.472	10,730	6,968	SEE#24	1.99
Production	5 1/2"	8 1/2"	.415	16,510	10,864	SEE#24	1.18
Tubing	2 3/8"			14,530	11,624		
Liners							

PACKERS

Kind:	N/A			
Sizes:	N/A			
Depths Set:	N/A			

ju
4/28/19

19) Describe proposed well work, including the drilling and plugging back of any pilot hole:

Drill through the Point Pleasant and TD Pilot Hole 150' into the Trenton. Log vertical section and run a solid cement plug back to proposed KOP. Drill curve and lateral per proposed well plan, run and cement production casing. Perform CBL from 60 deg to surface, make cleanout run, and stimulate.

20) Describe fracturing/stimulating methods in detail, including anticipated max pressure and max rate:

Well to be completed with approximately 27,590,000 lb proppant and 426,562 bbl of water. Max rate = 80 bpm; max psi = 12,000#.

21) Total Area to be disturbed, including roads, stockpile area, pits, etc., (acres): 11.56

22) Area to be disturbed for well pad only, less access road (acres): 5.81

23) Describe centralizer placement for each casing string:

Will run 3 centralizers on surface casing at equal distance. Intermediates will have 1 centralizer every third joint. Production casing will have one centralizer every third joint in lateral, one centralizer every joint through curve, one centralizer every third joint to surface.

24) Describe all cement additives associated with each cement type:

*See Attachment

25) Proposed borehole conditioning procedures:

Will circulate a minimum of 3 hours at TD, short trip to curve, circulate bottoms up, check for flow, POOH

*Note: Attach additional sheets as needed.



WELL NAME: Goudy 15-17HU
STATE: WV **COUNTY:** Marshall
DISTRICT: Franklin
DF Elev: 1,241' **GL Elev:** 1,241'
TD: 22,545'
TH Latitude: 39.73714731
TH Longitude: -80.82866243
BH Latitude: 39.708622
BH Longitude: -80.809961

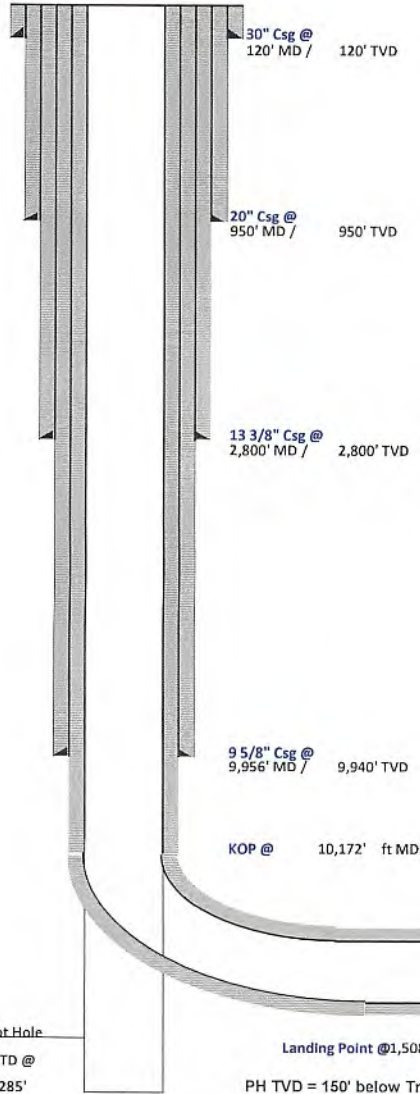

FORMATION TOPS	
Formation	Depth TVD
Deepest Fresh Water	862'
Sewickley Coal	757'
Pittsburgh Coal	856'
Big Lime	2,170'
Berea	2,713'
Tully	6,598'
Marcellus	6,627'
Onondaga	6,685'
Salina	7,199'
Lockport	8,190'
Utica	10,761'
Point Pleasant	11,006'
Landing Depth	11,056'
Trenton	11,135'
Pilot Hole TD	11,285'

CASING SUMMARY							
Type	Hole Size (in)	Csg Size (in)	Depth (MD)	Depth (TVD)	Weight (lb/ft)	Grade	Top of Cement
Conductor	36	30	120'	120'	BW	BW	Surface
Surface	26	20	950'	950'	106.5	J55	Surface
Intermediate 1	17 1/2	13 3/8	2,800'	2,800'	54.5	J55	Surface
Intermediate 2	12 3/8	9 5/8	9,956'	9,940'	47	HPP110	Surface
Production	8 1/2	5 1/2	22,545'	11,249'	23	HCP110	Surface

CEMENT SUMMARY				DRILLING DETAILS	
	Sacks	Class	Density	Fluid Type	Centralizer Notes
Conductor	338	A	15.6	Air	None
Surface	1,658	A	15.6	Air	3 Centralizers at equal distance
Intermediate 1	2,140	A	15	Air	1 Centralizer every other jt
Intermediate 2	2,871	A	14.5	Air	1 Centralizer every other jt
Production	4,728	A	15	Air / SOBM	1 every other joint in lateral; 1 per joint in curve; 1 every other jt to sfc

Handwritten signature and date: 6/28/19

Pilot Hole
PH TD @
11,285'

Landing Point @1,508' MD / 11,056' TVD
PH TVD = 150' below Trenton Top

Lateral TD @ 22,545' ft MD
11,249' ft TVD



Tug Hill Operating, LLC Casing and Cement Program

Goudy 1S-17HU

Casing

	String	Grade	Bit Size	Depth (Measured)	Cement Fill Up
Conductor	30"	BW	36"	120'	CTS
Surface	20"	J55	26"	950'	CTS
Intermediate 1	13 3/8"	J55	17 1/2"	2,800'	CTS
Intermediate 2	9 5/8"	HPP110	12 3/8"	9,956'	CTS
Production	5 1/2"	HCP110	8 1/2"	22,545'	CTS

Cement

Surface: Premium NE-1 + 2% bwoc CaC12 + 46.5% Fresh Water – Surface Cement mixed at 15.6 ppg, Y=1.2

Intermediate 1: Premium NE-1 + 1% bwoc CaC12 + 46.5% Fresh Water – Intermediate Cement mixed at 15.6 ppg, Y=1.2

Intermediate 2: Premium NE-1 + 1% bwoc CaC12 + 46.5% Fresh Water – Intermediate Cement mixed at 15.6 ppg, Y=1.99

Production: 50:50 Poz: Premium NE-1 + .1% bwoc ASA-301 + 60lb/sk ASCA-1 + .35% bwoc BA-10A + .25% bwoc MPA-170, 44 lb sack + .5% bwoc R-3 + .75 gals/100sk FP-13L – Production Cement mixed at 15.2ppg, Y = 1.18



UTICA APPLICATION

March 14, 2019

WV DEP OFFICE OF OIL & GAS
ATTENTION: LAURA ADKINS
601 57TH STREET SE
CHARLESTON WV 25304-2345

VIA USPS

RE: **Goudy 1S-17HU (New H6A Drilling Permit Application)**
Meade District, Marshall County, WV

Dear Laura:

Tug Hill Operating, LLC would like to submit the Goudy 1S-17HU application for a new well work permit to explore for Point Pleasant potential. The proposed well is located within Marshall County, WV. Please find the following enclosed:

- Check for application fee of \$5,150
- Permit application package
- CD with Site Safety Plans and MSDS Sheets
- Consent and Easement
- Map and list of names / addresses of all operators within 1,500 feet of entire well borehole
- Proposed Voluntary Pooling and Unitization Letter

Please note that the construction and E&S Plans for this pad were approved on 6/19/2018. Please see pages 1 & 10 attached as requested.

If you have any questions or need any additional information, please feel free to call me at (304) 376-0111. Thank you for taking your time to review this application.

Sincerely,

AMY L. MILLER
PERMITTING SPECIALIST-APPALACHIA REGION
TUG HILL OPERATING, LLC

RECEIVED
Office of Oil and Gas

MAR 21 2019

WV Department of
Environmental Protection

Enclosures



Well: Goudy 1S-17HU (N)
 Site: Goudy
 Project: Marshall County, West Virginia.
 Design: rev4
 Rig:

SECTION DETAILS

Sec	MD	Inc	Azi	TVD	+N/-S	+E/W	Dleg	TFace	VSect	Annotation
1	0.00	0.00	0.00	0.00	0.00	0.00	0.00	0.00	0.00	
2	3200.00	0.00	0.00	3200.00	0.00	0.00	0.00	0.00	0.00	KOP Begin 1°/100' build
3	3400.00	2.00	285.00	3399.96	0.90	-3.37	1.00	285.000	-2.39	Begin 2.00° tangent
4	4400.00	2.00	285.00	4399.35	9.94	-37.08	1.00	0.000	-28.27	Begin 1°/100' drop
5	4600.00	0.00	0.00	4599.31	10.84	-40.45	1.00	180.000	-28.66	Begin vertical hold
6	8500.00	0.00	0.00	8500.00	10.84	-40.45	1.00	0.000	-28.66	Begin 2°/100' build
7	8976.30	9.51	246.37	8973.43	-4.95	-76.54	2.00	246.373	-31.80	Begin 9.51° tangent
8	10172.10	9.51	246.37	10152.79	-84.15	-95.79	0.00	0.000	-47.51	Begin 8°/100' build/turn
9	11012.80	50.00	157.89	10885.50	-432.70	-194.89	6.00	-96.818	289.32	Begin 8°/100' build/turn
10	11508.47	89.00	149.80	11055.00	-838.85	-10.08	8.00	-12.421	744.12	Begin 89.00° lateral
11	22544.52	89.00	149.80	11249.00	-10375.53	5560.64	0.00	0.000	1771.68	PBHJTD 22544.52 MD/11249.00 TVD

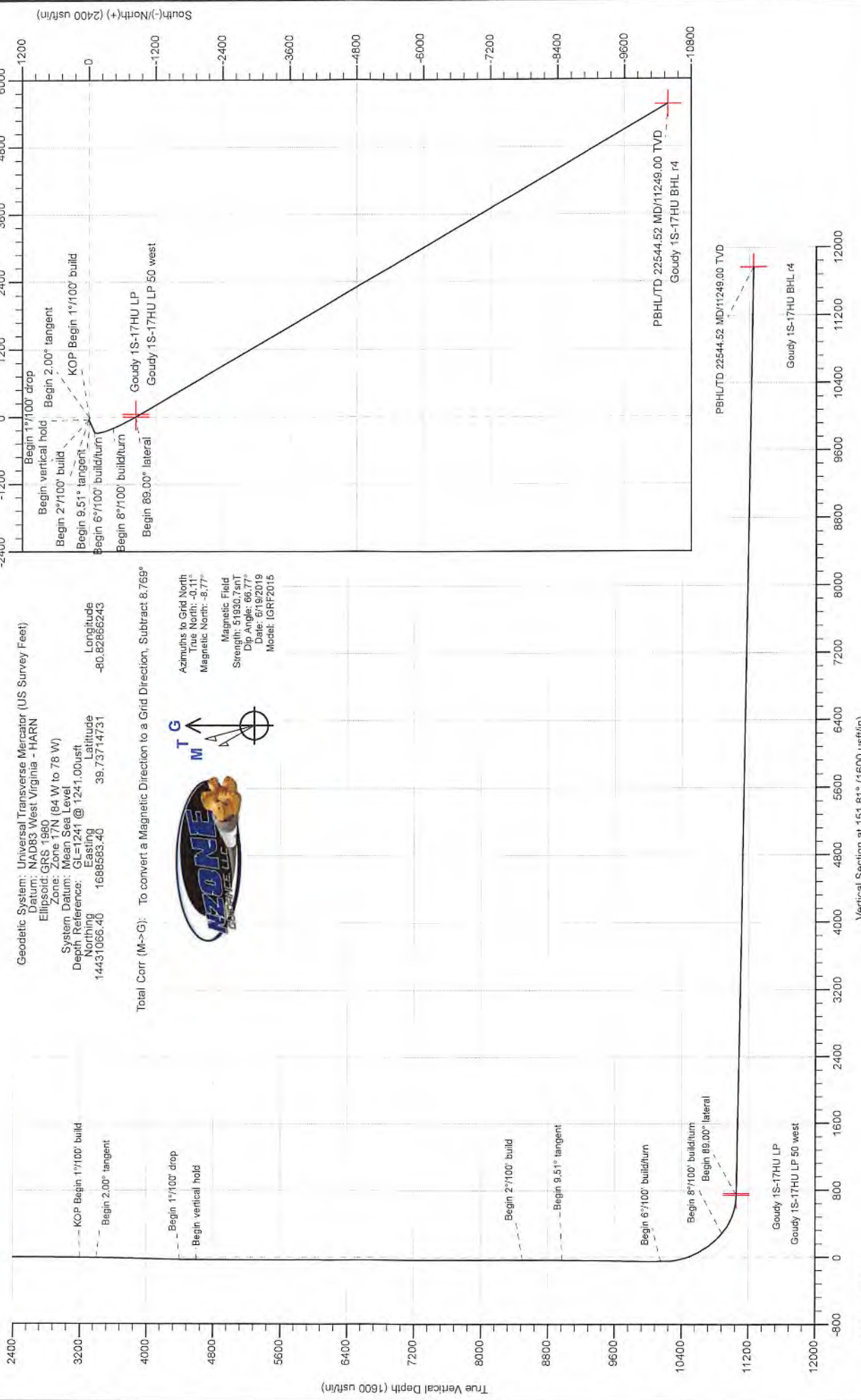

Geodetic System: Universal Transverse Mercator (US Survey Feet)
 Datum: NAD83 West Virginia - HARN
 Ellipsoid: GRS 1960
 Zone: Zone 17N (84 W to 78 W)
 System Datum: Mean Sea Level
 Depth Reference: GL-1241 @ 1241.00usft
 Northing: 14431066.40
 Easting: 1688583.40
 Latitude: 39.73714731
 Longitude: -80.82865243

Total Corr (M--G): To convert a Magnetic Direction to a Grid Direction, Subtract 8.769°
 Azimuths to Grid North
 True North: -0.11°
 Magnetic North: -8.77°
 Magnetic Field
 Strength: 51930.7snT
 Dip Angle: 66.77°
 Date: 6/19/2019
 Model: IGRF2015

Vertical Section at 151.81' (1600 usft/in)



Planning Report - Geographic

Database:	DB_Jul2216dt_v14	Local Co-ordinate Reference:	Well Goudy 1S-17HU (N)
Company:	Tug Hill Operating LLC	TVD Reference:	GL=1241 @ 1241.00usft
Project:	Marshall County, West Virginia.	MD Reference:	GL=1241 @ 1241.00usft
Site:	Goudy	North Reference:	Grid
Well:	Goudy 1S-17HU (N)	Survey Calculation Method:	Minimum Curvature
Wellbore:	Original Hole		
Design:	rev4		

Project	Marshall County, West Virginia.		
Map System:	Universal Transverse Mercator (US Survey Feet)	System Datum:	Mean Sea Level
Geo Datum:	NAD83 West Virginia - HARN		
Map Zone:	Zone 17N (84 W to 78 W)		

Site	Goudy				
Site Position:		Northing:	14,430,942.40 usft	Latitude:	39.73680688
From:	Lat/Long	Easting:	1,688,559.77 usft	Longitude:	-80.82874732
Position Uncertainty:	0.00 usft	Slot Radius:	13-3/16 "	Grid Convergence:	0.109 °

Well	Goudy 1S-17HU (N)					
Well Position	+N/-S	0.00 usft	Northing:	14,431,066.41 usft	Latitude:	39.73714731
	+E/-W	0.00 usft	Easting:	1,688,583.40 usft	Longitude:	-80.82866243
Position Uncertainty		0.00 usft	Wellhead Elevation:		Ground Level:	1,241.00 usft

Wellbore	Original Hole				
Magnetics	Model Name	Sample Date	Declination (°)	Dip Angle (°)	Field Strength (mT)
	IGRF2015	6/19/2019	-8.659	66.766	51,930.69637463

Design	rev4			
Audit Notes:				
Version:	Phase:	PLAN	Tie On Depth:	0.00
Vertical Section:	Depth From (TVD) (usft)	+N/-S (usft)	+E/-W (usft)	Direction (°)
	0.00	0.00	0.00	151.81

Plan Survey Tool Program	Date	6/18/2019		
Depth From (usft)	Depth To (usft)	Survey (Wellbore)	Tool Name	Remarks
1	0.00	22,544.52 rev4 (Original Hole)	MWD	
			MWD - Standard	



Planning Report - Geographic

Database:	DB_Jul2216dt_v14	Local Co-ordinate Reference:	Well Goudy 1S-17HU (N)
Company:	Tug Hill Operating LLC	TVD Reference:	GL=1241 @ 1241.00usft
Project:	Marshall County, West Virginia.	MD Reference:	GL=1241 @ 1241.00usft
Site:	Goudy	North Reference:	Grid
Well:	Goudy 1S-17HU (N)	Survey Calculation Method:	Minimum Curvature
Wellbore:	Original Hole		
Design:	rev4		

Plan Sections										
Measured Depth (usft)	Inclination (°)	Azimuth (°)	Vertical Depth (usft)	+N/-S (usft)	+E/-W (usft)	Dogleg Rate (°/100usft)	Build Rate (°/100usft)	Turn Rate (°/100usft)	TFO (°)	Target
0.00	0.00	0.00	0.00	0.00	0.00	0.00	0.00	0.00	0.00	
3,200.00	0.00	0.00	3,200.00	0.00	0.00	0.00	0.00	0.00	0.00	
3,400.00	2.00	285.00	3,399.96	0.90	-3.37	1.00	1.00	0.00	285.000	
4,400.00	2.00	285.00	4,399.35	9.94	-37.08	0.00	0.00	0.00	0.000	
4,600.00	0.00	0.00	4,599.31	10.84	-40.45	1.00	-1.00	0.00	180.000	
8,500.69	0.00	0.00	8,500.00	10.84	-40.45	0.00	0.00	0.00	0.000	
8,976.30	9.51	246.37	8,973.43	-4.95	-76.54	2.00	2.00	0.00	246.373	
10,172.10	9.51	246.37	10,152.79	-84.15	-257.59	0.00	0.00	0.00	0.000	
11,012.80	50.00	157.69	10,885.50	-432.70	-194.89	6.00	4.82	-10.55	-96.618	
11,508.47	89.00	149.80	11,056.00	-838.85	10.08	8.00	7.87	-1.59	-12.421	
22,544.52	89.00	149.80	11,249.00	-10,375.53	5,560.64	0.00	0.00	0.00	0.000	Goudy 1S-17HU BHL



Planning Report - Geographic

Database:	DB_Jul2216dt_v14	Local Co-ordinate Reference:	Well Goudy 1S-17HU (N)
Company:	Tug Hill Operating LLC	TVD Reference:	GL=1241 @ 1241.00usft
Project:	Marshall County, West Virginia.	MD Reference:	GL=1241 @ 1241.00usft
Site:	Goudy	North Reference:	Grid
Well:	Goudy 1S-17HU (N)	Survey Calculation Method:	Minimum Curvature
Wellbore:	Original Hole		
Design:	rev4		

Planned Survey										
Measured Depth (usft)	Inclination (°)	Azimuth (°)	Vertical Depth (usft)	+N/-S (usft)	+E/-W (usft)	Map Northing (usft)	Map Easting (usft)	Latitude	Longitude	
0.00	0.00	0.00	0.00	0.00	0.00	14,431,066.41	1,688,583.40	39.73714731	-80.82866243	
100.00	0.00	0.00	100.00	0.00	0.00	14,431,066.41	1,688,583.40	39.73714731	-80.82866243	
200.00	0.00	0.00	200.00	0.00	0.00	14,431,066.41	1,688,583.40	39.73714731	-80.82866243	
300.00	0.00	0.00	300.00	0.00	0.00	14,431,066.41	1,688,583.40	39.73714731	-80.82866243	
400.00	0.00	0.00	400.00	0.00	0.00	14,431,066.41	1,688,583.40	39.73714731	-80.82866243	
500.00	0.00	0.00	500.00	0.00	0.00	14,431,066.41	1,688,583.40	39.73714731	-80.82866243	
600.00	0.00	0.00	600.00	0.00	0.00	14,431,066.41	1,688,583.40	39.73714731	-80.82866243	
700.00	0.00	0.00	700.00	0.00	0.00	14,431,066.41	1,688,583.40	39.73714731	-80.82866243	
800.00	0.00	0.00	800.00	0.00	0.00	14,431,066.41	1,688,583.40	39.73714731	-80.82866243	
900.00	0.00	0.00	900.00	0.00	0.00	14,431,066.41	1,688,583.40	39.73714731	-80.82866243	
1,000.00	0.00	0.00	1,000.00	0.00	0.00	14,431,066.41	1,688,583.40	39.73714731	-80.82866243	
1,100.00	0.00	0.00	1,100.00	0.00	0.00	14,431,066.41	1,688,583.40	39.73714731	-80.82866243	
1,200.00	0.00	0.00	1,200.00	0.00	0.00	14,431,066.41	1,688,583.40	39.73714731	-80.82866243	
1,300.00	0.00	0.00	1,300.00	0.00	0.00	14,431,066.41	1,688,583.40	39.73714731	-80.82866243	
1,400.00	0.00	0.00	1,400.00	0.00	0.00	14,431,066.41	1,688,583.40	39.73714731	-80.82866243	
1,500.00	0.00	0.00	1,500.00	0.00	0.00	14,431,066.41	1,688,583.40	39.73714731	-80.82866243	
1,600.00	0.00	0.00	1,600.00	0.00	0.00	14,431,066.41	1,688,583.40	39.73714731	-80.82866243	
1,700.00	0.00	0.00	1,700.00	0.00	0.00	14,431,066.41	1,688,583.40	39.73714731	-80.82866243	
1,800.00	0.00	0.00	1,800.00	0.00	0.00	14,431,066.41	1,688,583.40	39.73714731	-80.82866243	
1,900.00	0.00	0.00	1,900.00	0.00	0.00	14,431,066.41	1,688,583.40	39.73714731	-80.82866243	
2,000.00	0.00	0.00	2,000.00	0.00	0.00	14,431,066.41	1,688,583.40	39.73714731	-80.82866243	
2,100.00	0.00	0.00	2,100.00	0.00	0.00	14,431,066.41	1,688,583.40	39.73714731	-80.82866243	
2,200.00	0.00	0.00	2,200.00	0.00	0.00	14,431,066.41	1,688,583.40	39.73714731	-80.82866243	
2,300.00	0.00	0.00	2,300.00	0.00	0.00	14,431,066.41	1,688,583.40	39.73714731	-80.82866243	
2,400.00	0.00	0.00	2,400.00	0.00	0.00	14,431,066.41	1,688,583.40	39.73714731	-80.82866243	
2,500.00	0.00	0.00	2,500.00	0.00	0.00	14,431,066.41	1,688,583.40	39.73714731	-80.82866243	
2,599.99	0.00	0.00	2,599.99	0.00	0.00	14,431,066.41	1,688,583.40	39.73714731	-80.82866243	
2,699.99	0.00	0.00	2,699.99	0.00	0.00	14,431,066.41	1,688,583.40	39.73714731	-80.82866243	
2,799.99	0.00	0.00	2,799.99	0.00	0.00	14,431,066.41	1,688,583.40	39.73714731	-80.82866243	
2,899.99	0.00	0.00	2,899.99	0.00	0.00	14,431,066.41	1,688,583.40	39.73714731	-80.82866243	
2,999.99	0.00	0.00	2,999.99	0.00	0.00	14,431,066.41	1,688,583.40	39.73714731	-80.82866243	
3,099.99	0.00	0.00	3,099.99	0.00	0.00	14,431,066.41	1,688,583.40	39.73714731	-80.82866243	
3,199.99	0.00	0.00	3,199.99	0.00	0.00	14,431,066.41	1,688,583.40	39.73714731	-80.82866243	
3,200.00	0.00	0.00	3,200.00	0.00	0.00	14,431,066.41	1,688,583.40	39.73714731	-80.82866243	
KOP Begin 1°/100' build										
3,299.99	1.00	285.00	3,299.99	0.23	-0.84	14,431,066.63	1,688,582.56	39.73714794	-80.82866543	
3,399.99	2.00	285.00	3,399.95	0.90	-3.37	14,431,067.31	1,688,580.03	39.73714981	-80.82867442	
3,400.00	2.00	285.00	3,399.96	0.90	-3.37	14,431,067.31	1,688,580.03	39.73714981	-80.82867442	
Begin 2.00° tangent										
3,499.99	2.00	285.00	3,499.89	1.81	-6.74	14,431,068.21	1,688,576.66	39.73715231	-80.82868640	
3,599.99	2.00	285.00	3,599.83	2.71	-10.11	14,431,069.12	1,688,573.29	39.73715481	-80.82869839	
3,699.99	2.00	285.00	3,699.77	3.61	-13.48	14,431,070.02	1,688,569.92	39.73715730	-80.82871037	
3,799.99	2.00	285.00	3,799.71	4.52	-16.86	14,431,070.92	1,688,566.55	39.73715980	-80.82872236	
3,899.99	2.00	285.00	3,899.65	5.42	-20.23	14,431,071.83	1,688,563.18	39.73716230	-80.82873434	
3,999.99	2.00	285.00	3,999.59	6.32	-23.60	14,431,072.73	1,688,559.80	39.73716480	-80.82874633	
4,099.99	2.00	285.00	4,099.52	7.23	-26.97	14,431,073.63	1,688,556.43	39.73716730	-80.82875831	
4,199.99	2.00	285.00	4,199.46	8.13	-30.34	14,431,074.54	1,688,553.06	39.73716980	-80.82877030	
4,299.99	2.00	285.00	4,299.40	9.03	-33.71	14,431,075.44	1,688,549.69	39.73717229	-80.82878228	
4,399.99	2.00	285.00	4,399.34	9.94	-37.08	14,431,076.34	1,688,546.32	39.73717479	-80.82879427	
4,400.00	2.00	285.00	4,399.35	9.94	-37.08	14,431,076.34	1,688,546.32	39.73717479	-80.82879427	
Begin 1°/100' drop										
4,499.99	1.00	285.00	4,499.31	10.61	-39.61	14,431,077.02	1,688,543.79	39.73717667	-80.82880326	
4,599.99	0.00	285.00	4,599.30	10.84	-40.45	14,431,077.25	1,688,542.95	39.73717729	-80.82880626	



Planning Report - Geographic

Database: DB_Jul2216dt_v14
 Company: Tug Hill Operating LLC
 Project: Marshall County, West Virginia.
 Site: Goudy
 Well: Goudy 1S-17HU (N)
 Wellbore: Original Hole
 Design: rev4

Local Co-ordinate Reference: Well Goudy 1S-17HU (N)
 TVD Reference: GL=1241 @ 1241.00usft
 MD Reference: GL=1241 @ 1241.00usft
 North Reference: Grid
 Survey Calculation Method: Minimum Curvature

Planned Survey

Measured Depth (usft)	Inclination (°)	Azimuth (°)	Vertical Depth (usft)	+N/-S (usft)	+E/-W (usft)	Map Northing (usft)	Map Easting (usft)	Latitude	Longitude
4,600.00	0.00	0.00	4,599.31	10.84	-40.45	14,431,077.25	1,688,542.95	39.73717729	-80.82880626
Begin vertical hold									
4,699.99	0.00	0.00	4,699.30	10.84	-40.45	14,431,077.25	1,688,542.95	39.73717729	-80.82880626
4,799.99	0.00	0.00	4,799.30	10.84	-40.45	14,431,077.25	1,688,542.95	39.73717729	-80.82880626
4,899.99	0.00	0.00	4,899.30	10.84	-40.45	14,431,077.25	1,688,542.95	39.73717729	-80.82880626
4,999.99	0.00	0.00	4,999.30	10.84	-40.45	14,431,077.25	1,688,542.95	39.73717729	-80.82880626
5,099.99	0.00	0.00	5,099.30	10.84	-40.45	14,431,077.25	1,688,542.95	39.73717729	-80.82880626
5,199.99	0.00	0.00	5,199.30	10.84	-40.45	14,431,077.25	1,688,542.95	39.73717729	-80.82880626
5,299.99	0.00	0.00	5,299.30	10.84	-40.45	14,431,077.25	1,688,542.95	39.73717729	-80.82880626
5,399.99	0.00	0.00	5,399.30	10.84	-40.45	14,431,077.25	1,688,542.95	39.73717729	-80.82880626
5,499.99	0.00	0.00	5,499.30	10.84	-40.45	14,431,077.25	1,688,542.95	39.73717729	-80.82880626
5,599.99	0.00	0.00	5,599.30	10.84	-40.45	14,431,077.25	1,688,542.95	39.73717729	-80.82880626
5,699.99	0.00	0.00	5,699.30	10.84	-40.45	14,431,077.25	1,688,542.95	39.73717729	-80.82880626
5,799.99	0.00	0.00	5,799.30	10.84	-40.45	14,431,077.25	1,688,542.95	39.73717729	-80.82880626
5,899.99	0.00	0.00	5,899.30	10.84	-40.45	14,431,077.25	1,688,542.95	39.73717729	-80.82880626
5,999.99	0.00	0.00	5,999.30	10.84	-40.45	14,431,077.25	1,688,542.95	39.73717729	-80.82880626
6,099.99	0.00	0.00	6,099.30	10.84	-40.45	14,431,077.25	1,688,542.95	39.73717729	-80.82880626
6,199.99	0.00	0.00	6,199.30	10.84	-40.45	14,431,077.25	1,688,542.95	39.73717729	-80.82880626
6,299.99	0.00	0.00	6,299.30	10.84	-40.45	14,431,077.25	1,688,542.95	39.73717729	-80.82880626
6,399.99	0.00	0.00	6,399.30	10.84	-40.45	14,431,077.25	1,688,542.95	39.73717729	-80.82880626
6,499.99	0.00	0.00	6,499.30	10.84	-40.45	14,431,077.25	1,688,542.95	39.73717729	-80.82880626
6,599.99	0.00	0.00	6,599.30	10.84	-40.45	14,431,077.25	1,688,542.95	39.73717729	-80.82880626
6,699.99	0.00	0.00	6,699.30	10.84	-40.45	14,431,077.25	1,688,542.95	39.73717729	-80.82880626
6,799.99	0.00	0.00	6,799.30	10.84	-40.45	14,431,077.25	1,688,542.95	39.73717729	-80.82880626
6,899.99	0.00	0.00	6,899.30	10.84	-40.45	14,431,077.25	1,688,542.95	39.73717729	-80.82880626
6,999.99	0.00	0.00	6,999.30	10.84	-40.45	14,431,077.25	1,688,542.95	39.73717729	-80.82880626
7,099.99	0.00	0.00	7,099.30	10.84	-40.45	14,431,077.25	1,688,542.95	39.73717729	-80.82880626
7,199.99	0.00	0.00	7,199.30	10.84	-40.45	14,431,077.25	1,688,542.95	39.73717729	-80.82880626
7,299.99	0.00	0.00	7,299.30	10.84	-40.45	14,431,077.25	1,688,542.95	39.73717729	-80.82880626
7,399.99	0.00	0.00	7,399.29	10.84	-40.45	14,431,077.25	1,688,542.95	39.73717729	-80.82880626
7,499.99	0.00	0.00	7,499.29	10.84	-40.45	14,431,077.25	1,688,542.95	39.73717729	-80.82880626
7,599.98	0.00	0.00	7,599.29	10.84	-40.45	14,431,077.25	1,688,542.95	39.73717729	-80.82880626
7,699.98	0.00	0.00	7,699.29	10.84	-40.45	14,431,077.25	1,688,542.95	39.73717729	-80.82880626
7,799.98	0.00	0.00	7,799.29	10.84	-40.45	14,431,077.25	1,688,542.95	39.73717729	-80.82880626
7,899.98	0.00	0.00	7,899.29	10.84	-40.45	14,431,077.25	1,688,542.95	39.73717729	-80.82880626
7,999.98	0.00	0.00	7,999.29	10.84	-40.45	14,431,077.25	1,688,542.95	39.73717729	-80.82880626
8,099.98	0.00	0.00	8,099.29	10.84	-40.45	14,431,077.25	1,688,542.95	39.73717729	-80.82880626
8,199.98	0.00	0.00	8,199.29	10.84	-40.45	14,431,077.25	1,688,542.95	39.73717729	-80.82880626
8,299.98	0.00	0.00	8,299.29	10.84	-40.45	14,431,077.25	1,688,542.95	39.73717729	-80.82880626
8,399.98	0.00	0.00	8,399.29	10.84	-40.45	14,431,077.25	1,688,542.95	39.73717729	-80.82880626
8,499.98	0.00	0.00	8,499.29	10.84	-40.45	14,431,077.25	1,688,542.95	39.73717729	-80.82880626
8,500.69	0.00	0.00	8,500.00	10.84	-40.45	14,431,077.25	1,688,542.95	39.73717729	-80.82880626
Begin 2°/100' build									
8,599.98	1.99	246.37	8,599.27	10.15	-42.03	14,431,076.56	1,688,541.37	39.73717541	-80.82881187
8,699.98	3.99	246.37	8,699.13	8.06	-46.80	14,431,074.47	1,688,536.60	39.73716970	-80.82882886
8,799.98	5.99	246.37	8,798.75	4.58	-54.76	14,431,070.99	1,688,528.64	39.73716017	-80.82885720
8,899.98	7.99	246.37	8,898.00	-0.30	-65.91	14,431,066.11	1,688,517.50	39.73714685	-80.82889687
8,976.30	9.51	246.37	8,973.43	-4.95	-76.54	14,431,061.46	1,688,506.86	39.73713413	-80.82893473
Begin 9.51° tangent									
8,999.98	9.51	246.37	8,996.78	-6.52	-80.13	14,431,059.89	1,688,503.28	39.73712984	-80.82894750
9,099.98	9.51	246.37	9,095.41	-13.14	-95.27	14,431,053.27	1,688,488.14	39.73711173	-80.82900140
9,199.98	9.51	246.37	9,194.03	-19.76	-110.41	14,431,046.64	1,688,473.00	39.73709362	-80.82905530
9,299.98	9.51	246.37	9,292.66	-26.39	-125.55	14,431,040.02	1,688,457.85	39.73707551	-80.82910920
9,399.98	9.51	246.37	9,391.28	-33.01	-140.69	14,431,033.40	1,688,442.71	39.73705740	-80.82916310



Planning Report - Geographic

Database:	DB_Jul2216dt_v14	Local Co-ordinate Reference:	Well Goudy 1S-17HU (N)
Company:	Tug Hill Operating LLC	TVD Reference:	GL=1241 @ 1241.00usft
Project:	Marshall County, West Virginia.	MD Reference:	GL=1241 @ 1241.00usft
Site:	Goudy	North Reference:	Grid
Well:	Goudy 1S-17HU (N)	Survey Calculation Method:	Minimum Curvature
Wellbore:	Original Hole		
Design:	rev4		

Planned Survey										
Measured Depth (usft)	Inclination (°)	Azimuth (°)	Vertical Depth (usft)	+N/-S (usft)	+E/-W (usft)	Map Northing (usft)	Map Easting (usft)	Latitude	Longitude	
9,499.98	9.51	246.37	9,489.91	-39.63	-155.83	14,431,026.77	1,688,427.57	39.73703929	-80.82921701	
9,599.98	9.51	246.37	9,588.53	-46.26	-170.97	14,431,020.15	1,688,412.43	39.73702118	-80.82927091	
9,699.98	9.51	246.37	9,687.16	-52.88	-186.11	14,431,013.53	1,688,397.29	39.73700307	-80.82932481	
9,799.98	9.51	246.37	9,785.78	-59.50	-201.25	14,431,006.90	1,688,382.15	39.73698496	-80.82937871	
9,899.98	9.51	246.37	9,884.41	-66.13	-216.39	14,431,000.28	1,688,367.01	39.73696685	-80.82943261	
9,999.98	9.51	246.37	9,983.03	-72.75	-231.53	14,430,993.66	1,688,351.87	39.73694874	-80.82948651	
10,099.98	9.51	246.37	10,081.66	-79.37	-246.67	14,430,987.04	1,688,336.73	39.73693062	-80.82954041	
10,172.10	9.51	246.37	10,152.79	-84.15	-257.59	14,430,982.26	1,688,325.81	39.73691756	-80.82957929	
Begin 6°/100' build/turn										
10,199.98	9.47	236.22	10,180.29	-86.35	-261.61	14,430,980.06	1,688,321.80	39.73691155	-80.82959359	
10,299.98	11.49	204.62	10,278.69	-99.98	-272.60	14,430,966.42	1,688,310.80	39.73687415	-80.82963279	
10,399.98	15.68	186.03	10,375.92	-122.49	-278.17	14,430,943.91	1,688,305.23	39.73681236	-80.82965277	
10,499.98	20.76	175.71	10,470.90	-153.63	-278.27	14,430,912.78	1,688,305.13	39.73672686	-80.82965331	
10,599.98	26.21	169.42	10,562.60	-193.04	-272.88	14,430,873.36	1,688,310.52	39.73661858	-80.82963442	
10,699.98	31.86	165.20	10,650.00	-240.31	-262.07	14,430,826.09	1,688,321.33	39.73648871	-80.82959628	
10,799.98	37.60	162.14	10,732.16	-294.92	-245.96	14,430,771.49	1,688,337.45	39.73633867	-80.82953934	
10,899.98	43.41	159.80	10,808.17	-356.25	-224.72	14,430,710.15	1,688,358.69	39.73617010	-80.82946419	
10,999.98	49.25	157.91	10,877.19	-423.66	-198.58	14,430,642.75	1,688,384.82	39.73598486	-80.82937168	
11,012.80	50.00	157.69	10,885.50	-432.70	-194.89	14,430,633.71	1,688,388.51	39.73596001	-80.82935862	
Begin 8°/100' build/turn										
11,099.98	56.83	155.90	10,937.43	-496.98	-167.28	14,430,569.43	1,688,416.12	39.73578334	-80.82926085	
11,199.98	64.68	154.17	10,986.26	-575.99	-130.44	14,430,490.42	1,688,452.96	39.73556616	-80.82913033	
11,299.98	72.55	152.64	11,022.69	-659.17	-88.76	14,430,407.24	1,688,494.65	39.73537500	-80.82898262	
11,399.98	80.44	151.24	11,046.02	-744.90	-43.04	14,430,321.51	1,688,540.36	39.73510183	-80.82882060	
11,499.98	88.33	149.91	11,055.80	-831.51	5.81	14,430,234.90	1,688,589.22	39.73486371	-80.82864741	
11,508.47	89.00	149.80	11,056.00	-838.85	10.08	14,430,227.56	1,688,593.48	39.73484353	-80.82863229	
Begin 89.00° lateral										
11,599.98	89.00	149.80	11,057.60	-917.92	56.10	14,430,148.48	1,688,639.50	39.73462612	-80.82846912	
11,699.98	89.00	149.80	11,059.35	-1,004.34	106.40	14,430,062.07	1,688,689.80	39.73438854	-80.82829081	
11,799.98	89.00	149.80	11,061.10	-1,090.75	156.69	14,429,975.66	1,688,740.09	39.73415095	-80.82811250	
11,899.98	89.00	149.80	11,062.85	-1,177.16	206.98	14,429,889.24	1,688,790.39	39.73391337	-80.82793419	
11,999.98	89.00	149.80	11,064.60	-1,263.58	257.28	14,429,802.83	1,688,840.68	39.73367579	-80.82775589	
12,099.98	89.00	149.80	11,066.34	-1,349.99	307.57	14,429,716.42	1,688,890.98	39.73343820	-80.82757758	
12,199.98	89.00	149.80	11,068.09	-1,436.41	357.87	14,429,630.00	1,688,941.27	39.73320062	-80.82739927	
12,299.98	89.00	149.80	11,069.84	-1,522.82	408.16	14,429,543.59	1,688,991.57	39.73296303	-80.82722097	
12,399.98	89.00	149.80	11,071.59	-1,609.23	458.46	14,429,457.17	1,689,041.86	39.73272545	-80.82704267	
12,499.98	89.00	149.80	11,073.34	-1,695.65	508.75	14,429,370.76	1,689,092.15	39.73248786	-80.82686437	
12,599.98	89.00	149.80	11,075.09	-1,782.06	559.05	14,429,284.35	1,689,142.45	39.73225028	-80.82668607	
12,699.97	89.00	149.80	11,076.84	-1,868.47	609.34	14,429,197.93	1,689,192.74	39.73201269	-80.82650777	
12,799.97	89.00	149.80	11,078.59	-1,954.89	659.64	14,429,111.52	1,689,243.04	39.73177510	-80.82632947	
12,899.97	89.00	149.80	11,080.33	-2,041.30	709.93	14,429,025.11	1,689,293.33	39.73153752	-80.82615117	
12,999.97	89.00	149.80	11,082.08	-2,127.72	760.23	14,428,938.69	1,689,343.63	39.73129993	-80.82597288	
13,099.97	89.00	149.80	11,083.83	-2,214.13	810.52	14,428,852.28	1,689,393.92	39.73106234	-80.82579458	
13,199.97	89.00	149.80	11,085.58	-2,300.54	860.82	14,428,765.86	1,689,444.22	39.73082475	-80.82561629	
13,299.97	89.00	149.80	11,087.33	-2,386.96	911.11	14,428,679.45	1,689,494.51	39.73058717	-80.82543800	
13,399.97	89.00	149.80	11,089.08	-2,473.37	961.41	14,428,593.04	1,689,544.81	39.73034958	-80.82525971	
13,499.97	89.00	149.80	11,090.83	-2,559.78	1,011.70	14,428,506.62	1,689,595.10	39.73011199	-80.82508142	
13,599.97	89.00	149.80	11,092.58	-2,646.20	1,061.99	14,428,420.21	1,689,645.40	39.72987440	-80.82490313	
13,699.97	89.00	149.80	11,094.33	-2,732.61	1,112.29	14,428,333.79	1,689,695.69	39.72963681	-80.82472485	
13,799.97	89.00	149.80	11,096.07	-2,819.03	1,162.58	14,428,247.38	1,689,745.99	39.72939922	-80.82454656	
13,899.97	89.00	149.80	11,097.82	-2,905.44	1,212.88	14,428,160.97	1,689,796.28	39.72916163	-80.82436828	
13,999.97	89.00	149.80	11,099.57	-2,991.85	1,263.17	14,428,074.55	1,689,846.58	39.72892404	-80.82418999	
14,099.97	89.00	149.80	11,101.32	-3,078.27	1,313.47	14,427,988.14	1,689,896.87	39.72868645	-80.82401171	
14,199.97	89.00	149.80	11,103.07	-3,164.68	1,363.76	14,427,901.73	1,689,947.17	39.72844886	-80.82383343	



Planning Report - Geographic

Database: DB_Jul2216dt_v14
 Company: Tug Hill Operating LLC
 Project: Marshall County, West Virginia.
 Site: Goudy
 Well: Goudy 1S-17HU (N)
 Wellbore: Original Hole
 Design: rev4

Local Co-ordinate Reference: Well Goudy 1S-17HU (N)
 TVD Reference: GL=1241 @ 1241.00usft
 MD Reference: GL=1241 @ 1241.00usft
 North Reference: Grid
 Survey Calculation Method: Minimum Curvature

Planned Survey									
Measured Depth (usft)	Inclination (°)	Azimuth (°)	Vertical Depth (usft)	+N/-S (usft)	+E/-W (usft)	Map Northing (usft)	Map Easting (usft)	Latitude	Longitude
14,299.97	89.00	149.80	11,104.82	-3,251.09	1,414.06	14,427,815.31	1,689,997.46	39.72821127	-80.82365515
14,399.97	89.00	149.80	11,106.57	-3,337.51	1,464.35	14,427,728.90	1,690,047.75	39.72797368	-80.82347687
14,499.97	89.00	149.80	11,108.32	-3,423.92	1,514.65	14,427,642.48	1,690,098.05	39.72773609	-80.82329860
14,599.97	89.00	149.80	11,110.06	-3,510.34	1,564.94	14,427,556.07	1,690,148.34	39.72749850	-80.82312032
14,699.97	89.00	149.80	11,111.81	-3,596.75	1,615.24	14,427,469.66	1,690,198.64	39.72726091	-80.82294205
14,799.97	89.00	149.80	11,113.56	-3,683.16	1,665.53	14,427,383.24	1,690,248.93	39.72702332	-80.82276377
14,899.97	89.00	149.80	11,115.31	-3,769.58	1,715.83	14,427,296.83	1,690,299.23	39.72678572	-80.82258550
14,999.97	89.00	149.80	11,117.06	-3,855.99	1,766.12	14,427,210.42	1,690,349.52	39.72654813	-80.82240723
15,099.97	89.00	149.80	11,118.81	-3,942.40	1,816.42	14,427,124.00	1,690,399.82	39.72631054	-80.82222896
15,199.97	89.00	149.80	11,120.56	-4,028.82	1,866.71	14,427,037.59	1,690,450.11	39.72607295	-80.82205069
15,299.97	89.00	149.80	11,122.31	-4,115.23	1,917.01	14,426,951.17	1,690,500.41	39.72583535	-80.82187243
15,399.97	89.00	149.80	11,124.06	-4,201.65	1,967.30	14,426,864.76	1,690,550.70	39.72559776	-80.82169416
15,499.97	89.00	149.80	11,125.80	-4,288.06	2,017.59	14,426,778.35	1,690,601.00	39.72536017	-80.82151590
15,599.97	89.00	149.80	11,127.55	-4,374.47	2,067.89	14,426,691.93	1,690,651.29	39.72512257	-80.82133763
15,699.97	89.00	149.80	11,129.30	-4,460.89	2,118.18	14,426,605.52	1,690,701.59	39.72488498	-80.82115937
15,799.97	89.00	149.80	11,131.05	-4,547.30	2,168.48	14,426,519.11	1,690,751.88	39.72464738	-80.82098111
15,899.97	89.00	149.80	11,132.80	-4,633.72	2,218.77	14,426,432.69	1,690,802.18	39.72440979	-80.82080285
15,999.97	89.00	149.80	11,134.55	-4,720.13	2,269.07	14,426,346.28	1,690,852.47	39.72417219	-80.82062459
16,099.97	89.00	149.80	11,136.30	-4,806.54	2,319.36	14,426,259.86	1,690,902.77	39.72393460	-80.82044633
16,199.97	89.00	149.80	11,138.05	-4,892.96	2,369.66	14,426,173.45	1,690,953.06	39.72369700	-80.82026808
16,299.97	89.00	149.80	11,139.79	-4,979.37	2,419.95	14,426,087.04	1,691,003.35	39.72345940	-80.82008982
16,399.97	89.00	149.80	11,141.54	-5,065.78	2,470.25	14,426,000.62	1,691,053.65	39.72322181	-80.81991157
16,499.97	89.00	149.80	11,143.29	-5,152.20	2,520.54	14,425,914.21	1,691,103.94	39.72298421	-80.81973332
16,599.97	89.00	149.80	11,145.04	-5,238.61	2,570.84	14,425,827.79	1,691,154.24	39.72274661	-80.81955507
16,699.97	89.00	149.80	11,146.79	-5,325.03	2,621.13	14,425,741.38	1,691,204.53	39.72250902	-80.81937682
16,799.97	89.00	149.80	11,148.54	-5,411.44	2,671.43	14,425,654.97	1,691,254.83	39.72227142	-80.81919857
16,899.97	89.00	149.80	11,150.29	-5,497.85	2,721.72	14,425,568.55	1,691,305.12	39.72203382	-80.81902032
16,999.97	89.00	149.80	11,152.04	-5,584.27	2,772.02	14,425,482.14	1,691,355.42	39.72179622	-80.81884207
17,099.97	89.00	149.80	11,153.78	-5,670.68	2,822.31	14,425,395.73	1,691,405.71	39.72155862	-80.81866383
17,199.97	89.00	149.80	11,155.53	-5,757.09	2,872.61	14,425,309.31	1,691,456.01	39.72132103	-80.81848558
17,299.97	89.00	149.80	11,157.28	-5,843.51	2,922.90	14,425,222.90	1,691,506.30	39.72108343	-80.81830734
17,399.97	89.00	149.80	11,159.03	-5,929.92	2,973.19	14,425,136.48	1,691,556.60	39.72084583	-80.81812910
17,499.97	89.00	149.80	11,160.78	-6,016.34	3,023.49	14,425,050.07	1,691,606.89	39.72060823	-80.81795086
17,599.97	89.00	149.80	11,162.53	-6,102.75	3,073.78	14,424,963.66	1,691,657.19	39.72037063	-80.81777262
17,699.96	89.00	149.80	11,164.28	-6,189.16	3,124.08	14,424,877.24	1,691,707.48	39.72013303	-80.81759438
17,799.96	89.00	149.80	11,166.03	-6,275.58	3,174.37	14,424,790.83	1,691,757.78	39.71989543	-80.81741615
17,899.96	89.00	149.80	11,167.78	-6,361.99	3,224.67	14,424,704.42	1,691,808.07	39.71965783	-80.81723791
17,999.96	89.00	149.80	11,169.52	-6,448.40	3,274.96	14,424,618.00	1,691,858.36	39.71942023	-80.81705968
18,099.96	89.00	149.80	11,171.27	-6,534.82	3,325.26	14,424,531.59	1,691,908.66	39.71918262	-80.81688144
18,199.96	89.00	149.80	11,173.02	-6,621.23	3,375.55	14,424,445.17	1,691,958.95	39.71894502	-80.81670321
18,299.96	89.00	149.80	11,174.77	-6,707.65	3,425.85	14,424,358.76	1,692,009.25	39.71870742	-80.81652498
18,399.96	89.00	149.80	11,176.52	-6,794.06	3,476.14	14,424,272.35	1,692,059.54	39.71846982	-80.81634675
18,499.96	89.00	149.80	11,178.27	-6,880.47	3,526.44	14,424,185.93	1,692,109.84	39.71823222	-80.81616852
18,599.96	89.00	149.80	11,180.02	-6,966.89	3,576.73	14,424,099.52	1,692,160.13	39.71799461	-80.81599030
18,699.96	89.00	149.80	11,181.77	-7,053.30	3,627.03	14,424,013.11	1,692,210.43	39.71775701	-80.81581207
18,799.96	89.00	149.80	11,183.51	-7,139.71	3,677.32	14,423,926.69	1,692,260.72	39.71751941	-80.81563385
18,899.96	89.00	149.80	11,185.26	-7,226.13	3,727.62	14,423,840.28	1,692,311.02	39.71728180	-80.81545562
18,999.96	89.00	149.80	11,187.01	-7,312.54	3,777.91	14,423,753.86	1,692,361.31	39.71704420	-80.81527740
19,099.96	89.00	149.80	11,188.76	-7,398.96	3,828.20	14,423,667.45	1,692,411.61	39.71680660	-80.81509918
19,199.96	89.00	149.80	11,190.51	-7,485.37	3,878.50	14,423,581.04	1,692,461.90	39.71656899	-80.81492096
19,299.96	89.00	149.80	11,192.26	-7,571.78	3,928.79	14,423,494.62	1,692,512.20	39.71633139	-80.81474274
19,399.96	89.00	149.80	11,194.01	-7,658.20	3,979.09	14,423,408.21	1,692,562.49	39.71609378	-80.81456453
19,499.96	89.00	149.80	11,195.76	-7,744.61	4,029.38	14,423,321.80	1,692,612.79	39.71585618	-80.81438631
19,599.96	89.00	149.80	11,197.51	-7,831.03	4,079.68	14,423,235.38	1,692,663.08	39.71561857	-80.81420810
19,699.96	89.00	149.80	11,199.25	-7,917.44	4,129.97	14,423,148.97	1,692,713.38	39.71538097	-80.81402988



Planning Report - Geographic

Database:	DB_Jul2216dt_v14	Local Co-ordinate Reference:	Well Goudy 1S-17HU (N)
Company:	Tug Hill Operating LLC	TVD Reference:	GL=1241 @ 1241.00usft
Project:	Marshall County, West Virginia.	MD Reference:	GL=1241 @ 1241.00usft
Site:	Goudy	North Reference:	Grid
Well:	Goudy 1S-17HU (N)	Survey Calculation Method:	Minimum Curvature
Wellbore:	Original Hole		
Design:	rev4		

Planned Survey										
Measured Depth (usft)	Inclination (°)	Azimuth (°)	Vertical Depth (usft)	+N/-S (usft)	+E/-W (usft)	Map Northing (usft)	Map Easting (usft)	Latitude	Longitude	
19,799.96	89.00	149.80	11,201.00	-8,003.85	4,180.27	14,423,062.55	1,692,763.67	39.71514336	-80.81385167	
19,899.96	89.00	149.80	11,202.75	-8,090.27	4,230.56	14,422,976.14	1,692,813.96	39.71490575	-80.81367346	
19,999.96	89.00	149.80	11,204.50	-8,176.68	4,280.86	14,422,889.73	1,692,864.26	39.71466815	-80.81349525	
20,099.96	89.00	149.80	11,206.25	-8,263.09	4,331.15	14,422,803.31	1,692,914.55	39.71443054	-80.81331704	
20,199.96	89.00	149.80	11,208.00	-8,349.51	4,381.45	14,422,716.90	1,692,964.85	39.71419293	-80.81313883	
20,299.96	89.00	149.80	11,209.75	-8,435.92	4,431.74	14,422,630.48	1,693,015.14	39.71395533	-80.81296063	
20,399.96	89.00	149.80	11,211.50	-8,522.34	4,482.04	14,422,544.07	1,693,065.44	39.71371772	-80.81278242	
20,499.96	89.00	149.80	11,213.24	-8,608.75	4,532.33	14,422,457.66	1,693,115.73	39.71348011	-80.81260422	
20,599.96	89.00	149.80	11,214.99	-8,695.16	4,582.63	14,422,371.24	1,693,166.03	39.71324250	-80.81242602	
20,699.96	89.00	149.80	11,216.74	-8,781.58	4,632.92	14,422,284.83	1,693,216.32	39.71300489	-80.81224782	
20,799.96	89.00	149.80	11,218.49	-8,867.99	4,683.22	14,422,198.42	1,693,266.62	39.71276728	-80.81206962	
20,899.96	89.00	149.80	11,220.24	-8,954.40	4,733.51	14,422,112.00	1,693,316.91	39.71252968	-80.81189142	
20,999.96	89.00	149.80	11,221.99	-9,040.82	4,783.80	14,422,025.59	1,693,367.21	39.71229207	-80.81171322	
21,099.96	89.00	149.80	11,223.74	-9,127.23	4,834.10	14,421,939.17	1,693,417.50	39.71205446	-80.81153502	
21,199.96	89.00	149.80	11,225.49	-9,213.65	4,884.39	14,421,852.76	1,693,467.80	39.71181685	-80.81135683	
21,299.96	89.00	149.80	11,227.24	-9,300.06	4,934.69	14,421,766.35	1,693,518.09	39.71157924	-80.81117864	
21,399.96	89.00	149.80	11,228.98	-9,386.47	4,984.98	14,421,679.93	1,693,568.39	39.71134163	-80.81100044	
21,499.96	89.00	149.80	11,230.73	-9,472.89	5,035.28	14,421,593.52	1,693,618.68	39.71110402	-80.81082225	
21,599.96	89.00	149.80	11,232.48	-9,559.30	5,085.57	14,421,507.11	1,693,668.98	39.71086640	-80.81064406	
21,699.96	89.00	149.80	11,234.23	-9,645.71	5,135.87	14,421,420.69	1,693,719.27	39.71062879	-80.81046587	
21,799.96	89.00	149.80	11,235.98	-9,732.13	5,186.16	14,421,334.28	1,693,769.56	39.71039118	-80.81028768	
21,899.96	89.00	149.80	11,237.73	-9,818.54	5,236.46	14,421,247.86	1,693,819.86	39.71015357	-80.81010950	
21,999.96	89.00	149.80	11,239.48	-9,904.96	5,286.75	14,421,161.45	1,693,870.15	39.70991596	-80.80993131	
22,099.96	89.00	149.80	11,241.23	-9,991.37	5,337.05	14,421,075.04	1,693,920.45	39.70967834	-80.80975313	
22,199.96	89.00	149.80	11,242.97	-10,077.78	5,387.34	14,420,988.62	1,693,970.74	39.70944073	-80.80957495	
22,299.96	89.00	149.80	11,244.72	-10,164.20	5,437.64	14,420,902.21	1,694,021.04	39.70920312	-80.80939676	
22,399.96	89.00	149.80	11,246.47	-10,250.61	5,487.93	14,420,815.80	1,694,071.33	39.70896551	-80.80921858	
22,499.96	89.00	149.80	11,248.22	-10,337.03	5,538.23	14,420,729.38	1,694,121.63	39.70872789	-80.80904041	
22,544.52	89.00	149.80	11,249.00	-10,375.53	5,560.64	14,420,690.87	1,694,144.04	39.70862200	-80.80896100	
PBHL/TD 22544.52 MD/11249.00 TVD										

Design Targets										
Target Name	Dip Angle (°)	Dip Dir. (°)	TVD (usft)	+N/-S (usft)	+E/-W (usft)	Northing (usft)	Easting (usft)	Latitude	Longitude	
Goudy 1S-17HU LP - hit/miss target - Shape - Point	0.00	0.00	11,056.00	-838.81	60.11	14,430,227.59	1,688,643.51	39.73484336	-80.82845431	
- plan misses target center by 43.26usft at 11533.60usft MD (11056.44 TVD, -860.57 N, 22.72 E)										
Goudy 1S-17HU LP 50 \	0.00	0.00	11,056.00	-838.81	10.11	14,430,227.59	1,688,593.51	39.73484362	-80.82863216	
- plan misses target center by 0.05usft at 11508.46usft MD (11056.00 TVD, -838.84 N, 10.07 E)										
Goudy 1S-17HU BHL r4 - plan hits target center - Point	0.00	0.00	11,249.00	-10,375.53	5,560.64	14,420,690.87	1,694,144.04	39.70862200	-80.80896100	



Planning Report - Geographic

Database:	DB_Jul2216dt_v14	Local Co-ordinate Reference:	Well Goudy 1S-17HU (N)
Company:	Tug Hill Operating LLC	TVD Reference:	GL=1241 @ 1241.00usft
Project:	Marshall County, West Virginia.	MD Reference:	GL=1241 @ 1241.00usft
Site:	Goudy	North Reference:	Grid
Well:	Goudy 1S-17HU (N)	Survey Calculation Method:	Minimum Curvature
Wellbore:	Original Hole		
Design:	rev4		

Casing Points					
Measured Depth (usft)	Vertical Depth (usft)	Name	Casing Diameter (")	Hole Diameter (")	
1,000.00	1,000.00	20" Casing	20	26	
2,950.00	2,950.00	13 3/8" Casing	13-3/8	17	
9,865.09	9,850.00	9 5/8" Casing	9-5/8	12-1/4	

Plan Annotations					
Measured Depth (usft)	Vertical Depth (usft)	Local Coordinates		Comment	
		+N/-S (usft)	+E/-W (usft)		
3,200.00	3,200.00	0.00	0.00	KOP Begin 1°/100' build	
3,400.00	3,399.96	0.90	-3.37	Begin 2.00° tangent	
4,400.00	4,399.35	9.94	-37.08	Begin 1°/100' drop	
4,600.00	4,599.31	10.84	-40.45	Begin vertical hold	
8,500.69	8,500.00	10.84	-40.45	Begin 2°/100' build	
8,976.30	8,973.43	-4.95	-76.54	Begin 9.51° tangent	
10,172.10	10,152.79	-84.15	-257.59	Begin 6°/100' build/turn	
11,012.80	10,885.50	-432.70	-194.89	Begin 8°/100' build/turn	
11,508.47	11,056.00	-838.85	10.08	Begin 89.00° lateral	
22,544.52	11,249.00	-10,375.53	5,560.64	PBHL/TD 22544.52 MD/11249.00 TVD	

WW-9
(4/16)

API Number 47 - 051 - _____
Operator's Well No. Goudy 1S-17HU

STATE OF WEST VIRGINIA
DEPARTMENT OF ENVIRONMENTAL PROTECTION
OFFICE OF OIL AND GAS

FLUIDS/ CUTTINGS DISPOSAL & RECLAMATION PLAN

Operator Name Tug Hill Operating, LLC OP Code 494510851

Watershed (HUC 10) French Creek - Ohio River Quadrangle New Martinsville 7.5'

Do you anticipate using more than 5,000 bbls of water to complete the proposed well work? Yes No

Will a pit be used? Yes No

If so, please describe anticipated pit waste: AST Tanks with proper containment will be used for staging fresh water for frac and flow back water

Will a synthetic liner be used in the pit? Yes No If so, what ml.? AST Tanks will be used with proper contain⁺

Proposed Disposal Method For Treated Pit Wastes:

- Land Application
- Underground Injection (UIC Permit Number UIC 2459, UIC 965, UIC 359, UIC 2D0732540, UIC 2D0732523)
- Reuse (at API Number _____)
- Off Site Disposal (Supply form WW-9 for disposal location)
- Other (Explain _____)

Will closed loop system be used? If so, describe: Yes - For Vertical and Horizontal Drilling

Drilling medium anticipated for this well (vertical and horizontal)? Air, freshwater, oil based, etc. Air for vertical / Oil for Horizontal

-If oil based, what type? Synthetic, petroleum, etc. Synthetic Oil Base

Additives to be used in drilling medium? Barite for weight

Drill cuttings disposal method? Leave in pit, landfill, removed offsite, etc. All drill cuttings to be disposed of in a Landfill

-If left in pit and plan to solidify what medium will be used? (cement, lime, sawdust) N/A

-Landfill or offsite name/permit number? Wetzel County Sanitary Landfill (SWF-1021 / WV0109185) and Westmoreland Sanitary Landfill, LLC (SAN1405 / PA DEP EC#1386426)

Permittee shall provide written notice to the Office of Oil and Gas of any load of drill cuttings or associated waste rejected at any West Virginia solid waste facility. The notice shall be provided within 24 hours of rejection and the permittee shall also disclose where it was properly disposed.

I certify that I understand and agree to the terms and conditions of the GENERAL WATER POLLUTION PERMIT issued on August 1, 2005, by the Office of Oil and Gas of the West Virginia Department of Environmental Protection. I understand that the provisions of the permit are enforceable by law. Violations of any term or condition of the general permit and/or other applicable law or regulation can lead to enforcement action.

I certify under penalty of law that I have personally examined and am familiar with the information submitted on this application form and all attachments thereto and that, based on my inquiry of those individuals immediately responsible for obtaining the information, I believe that the information is true, accurate, and complete. I am aware that there are significant penalties for submitting false information, including the possibility of fine or imprisonment.

Company Official Signature Jim Pancake

Company Official (Typed Name) Jim Pancake

Company Official Title Vice President Geoscience

MAR 21 2019

Office of Oil and Gas
WV Department of Environmental Protection

Subscribed and sworn before me this 29 day of JANUARY, 2019

Maureen A Stead

Notary Public

My commission expires 1/28/23

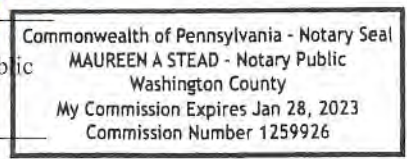

Form WW-9

Operator's Well No. Goudy 1S-17HU

Tug Hill Operating, LLC

Proposed Revegetation Treatment: Acres Disturbed 11.56 Prevegetation pH 6.0

Lime 3 Tons/acre or to correct to pH 6.5

Fertilizer type 10-20-20

Fertilizer amount 500 lbs/acre

Mulch 2.5 Tons/acre

Seed Mixtures

Temporary		Permanent	
Seed Type	lbs/acre	Seed Type	lbs/acre
Annual Ryegrass	40	Orchard Grass	12
Spring Oats	96	Ladino	3
		White Clover	2

Attach:

Maps(s) of road, location, pit and proposed area for land application (unless engineered plans including this info have been provided). If water from the pit will be land applied, include dimensions (L x W x D) of the pit, and dimensions (L x W), and area in acreage, of the land application area.

Photocopied section of involved 7.5' topographic sheet.

Plan Approved by: *Jim Anderson*

Comments: _____

RECEIVED
Office of Oil and Gas

MAR 21 2019

WV Department of
Environmental Protection

Title: Oil and Gas Inspector

Date: 2/7/19

Field Reviewed? () Yes () No

WW-9

PROPOSED GOUDY 1S-17HU

SUPPLEMENT PG 1

DRAWING NOT
TO SCALE

REFERENCE IS HEREBY MADE TO THE WV D.E.P. OFFICE OF OIL & GAS, "EROSION AND SEDIMENT CONTROL FIELD MANUAL" FOR REQUIREMENTS AND BMPs FOR AVERAGE FIELD CONDITIONS CONCERNING THE MAINTENANCE OF EXISTING ROADS AND THE CONSTRUCTION OF PROPOSED ROADS. FIELD CONDITIONS MAY REQUIRE VARIANCE FROM THESE GUIDELINES AND THE EARTHWORK CONTRACTOR IS RESPONSIBLE FOR NOTIFICATION TO THE INSPECTOR AND THE OPERATOR SHOULD THESE CONDITIONS OCCUR.

INSTALL CULVERTS AS SHOWN ON RECLAMATION PLAN OR AS FIELD CONDITIONS REQUIRE.

ENTRANCES ONTO PUBLIC ROADS SHALL BE CONSTRUCTED OR MAINTAINED IN ACCORDANCE WITH WV D.O.T. REGULATIONS. ADDITIONAL PERMITS MAY BE REQUIRED. TEMPORARILY SEED AND MULCH ALL SLOPES UPON CONSTRUCTION OF LOCATION.

ALL CUT AND FILL SLOPES ARE 2H : 1V SLOPE.

ALL TREES 6-INCHES AND ABOVE ARE TO BE CUT AND STACKED. BRUSH SLASHINGS ARE TO UTILIZED DOWN SLOPE OF SITE AND STRUCTURES TO ACT AS A CONTROL BARRIER IF AVAILABLE.

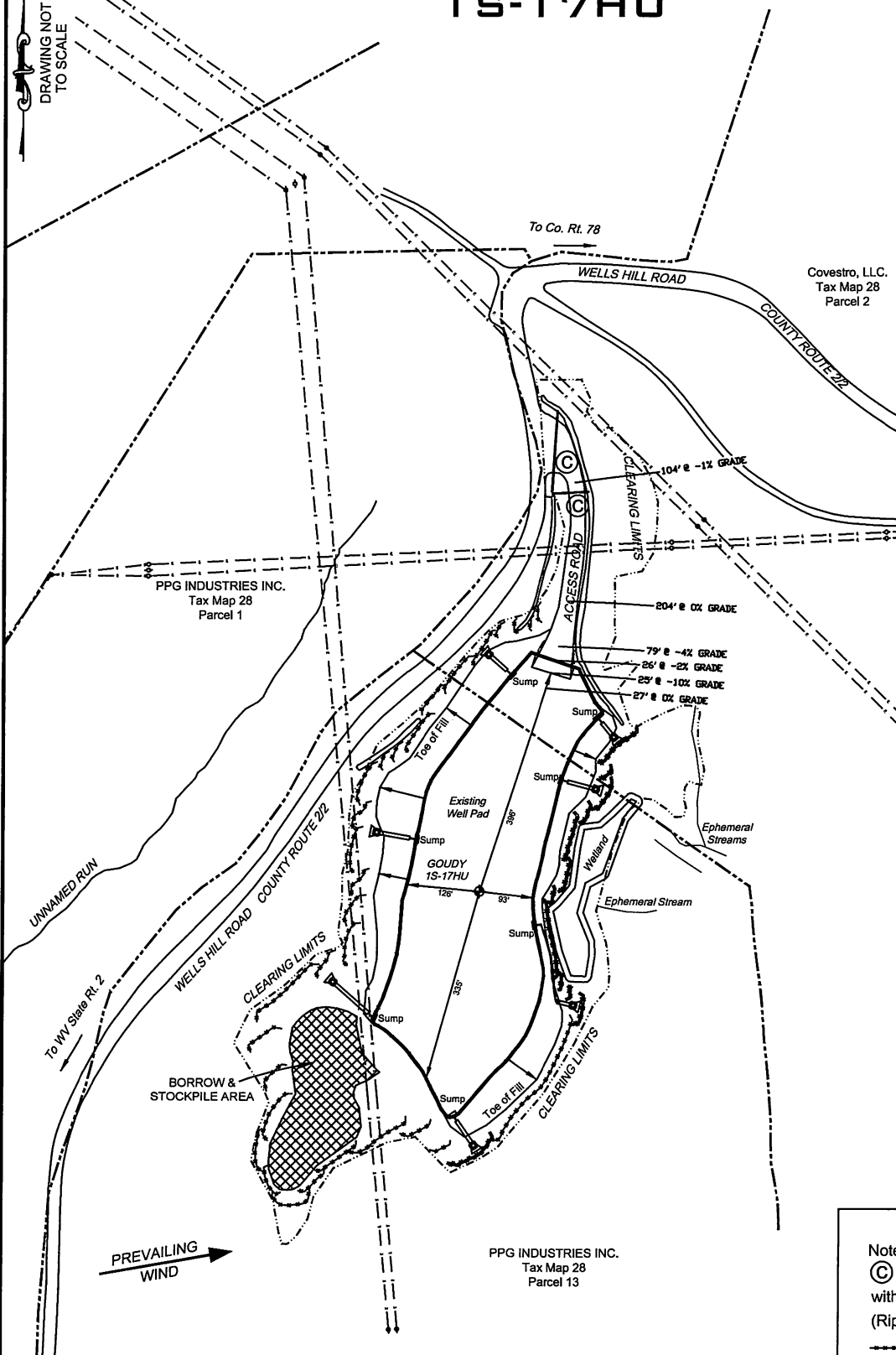

RECEIVED
Office of Oil and Gas

MAR 21 2019

WV Department of
Environmental Protection

LEGEND

Note:

Ⓢ — Denotes existing culvert with appropriate sediment outlet control (Rip Rap splash pad).

----- Silt Fence and or Sediment and Erosion Control Measure.

----- Surface Boundary

— E — Overhead Utility

DATE: 01/25/2019

PROJECT NO: 494510851

DRAWN BY: J.A.H.



Well Site Safety Plan

Tug Hill Operating, LLC

ju 2/7/19

Well Name: Goudy 1S-17HU

Pad Location: Goudy

Marshall County, West Virginia

UTM (meters), NAD83, Zone 17:

NORTHING - 4,398,597.84

EASTING - 514,681.25

January 2019

RECEIVED
Office of Oil and Gas

MAR 21 2019

WV Department of
Environmental Protection

GOUDY LEASE WELL 1S-17HU 366.3537± ACRES

DETAIL SKETCH "A"
SCALE 1"=200'

REFERENCES SCALE 1"=200'

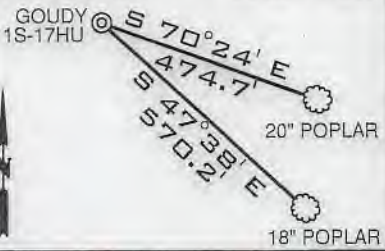

- 01S-18HU (02197)
- 01N-15HU (02200)
- 01N-13HU (02198)
- 01S-17HU (02195)
- 01S-16HU (02195)
- 01S-12HU (02050)
- 01S-10HM
- 01S-9HM
- 01S-11HM (01588)
- 07H (01588)
- 10H (01594)
- 9H (01590)
- 6H (01589)
- 5H (01591)
- 4H (01592)
- 3H (01593)
- 2H (01601)
- 1H (01610)

(BH) BOTTOM HOLE LONGITUDE: 80°47'30"
(TH) TOP HOLE LONGITUDE: 80°47'30"
(TH) 4,700'
(BH) 15,092'

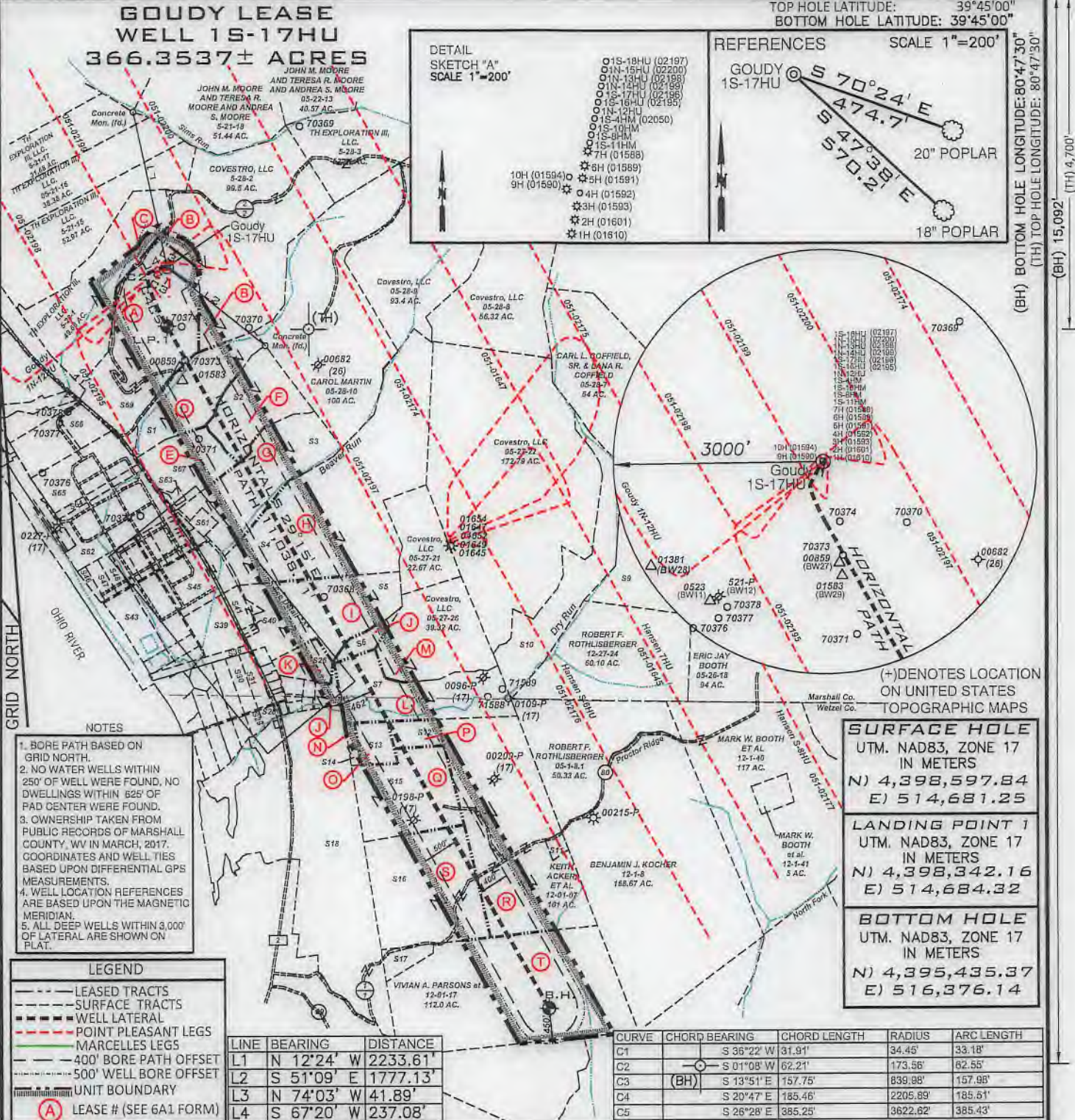

- NOTES**
1. BORE PATH BASED ON GRID NORTH.
 2. NO WATER WELLS WITHIN 250' OF WELL WERE FOUND, NO DWELLINGS WITHIN 625' OF PAD CENTER WERE FOUND.
 3. OWNERSHIP TAKEN FROM PUBLIC RECORDS OF MARSHALL COUNTY, WV IN MARCH, 2017. COORDINATES AND WELL TIES BASED UPON DIFFERENTIAL GPS MEASUREMENTS.
 4. WELL LOCATION REFERENCES ARE BASED UPON THE MAGNETIC MERIDIAN.
 5. ALL DEEP WELLS WITHIN 3,000' OF LATERAL ARE SHOWN ON PLAT.

LEGEND

- LEASED TRACTS
- SURFACE TRACTS
- WELL LATERAL
- POINT PLEASANT LEGS
- MARCELLES LEGS
- 400' BORE PATH OFFSET
- 500' WELL BORE OFFSET
- UNIT BOUNDARY
- (A) LEASE # (SEE 6A1 FORM)

LINE	BEARING	DISTANCE
L1	N 12°24' W	2233.61'
L2	S 51°09' E	1777.13'
L3	N 74°03' W	41.89'
L4	S 67°20' W	237.08'

CURVE	CHORD BEARING	CHORD LENGTH	RADIUS	ARC LENGTH
C1	S 36°22' W	31.91'	34.45'	33.18'
C2	S 01°08' W	62.21'	173.56'	62.55'
C3	(BH) S 13°51' E	157.75'	839.98'	157.98'
C4	S 20°47' E	185.46'	2205.89'	185.51'
C5	S 26°28' E	385.25'	3622.62'	385.43'

(+) DENOTES LOCATION ON UNITED STATES TOPOGRAPHIC MAPS

SURFACE HOLE UTM. NAD83, ZONE 17 IN METERS N) 4,398,597.84 E) 514,681.25
LANDING POINT 1 UTM. NAD83, ZONE 17 IN METERS N) 4,398,342.16 E) 514,684.32
BOTTOM HOLE UTM. NAD83, ZONE 17 IN METERS N) 4,395,435.37 E) 516,376.14

FILE NUMBER _____

DRAWING NUMBER GOUDY_1S-17HU_REV4

SCALE 1" = 2000'

MINIMUM DEGREE OF ACCURACY 1/200

PROVEN SOURCE OF ELEVATION SUBMETER MAPPING
GRADE GPS

I, THE UNDERSIGNED, HEREBY CERTIFY THAT THIS PLAT IS CORRECT TO THE BEST OF MY KNOWLEDGE AND BELIEF AND SHOWS ALL THE INFORMATION REQUIRED BY LAW AND THE RULES ISSUED AND PRESCRIBED BY THE DEPARTMENT OF ENVIRONMENTAL PROTECTION

P.S. 708 *David L Jackson*

JACKSON SURVEYING INC.
P.O. Box 1460
Clarksburg, WV 26302
304-623-5851

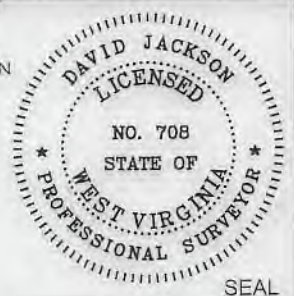

WVDEP
OFFICE OF OIL & GAS
601 57TH STREET, SE
CHARLESTON, WV 25304

WELL TYPE: OIL ___ GAS X LIQUID INJECTION ___ WASTE DISPOSAL ___
(IF "GAS") PRODUCTION X STORAGE ___ DEEP X SHALLOW ___

LOCATION ELEVATION 1239.4' WATERSHED (HUC 10) FRENCH CREEK - OHIO RIVER

DISTRICT FRANKLIN COUNTY MARSHALL

QUADRANGLE NEW MARTINSVILLE 7.5' LEASE NUMBER _____ SEE WW-6A1 FORM

SURFACE OWNER TH EXPLORATION III, LLC. ACREAGE 70.0

OIL & GAS ROYALTY OWNER TH EXPLORATION III, LLC. LEASE ACREAGE 70.0

PROPOSED WORK: DRILL X CONVERT ___ DRILL DEEPER ___ REDRILL ___ FRACTURE OR STIMULATE X PLUG OFF OLD FORMATION ___
PERFORATE NEW FORMATION ___ OTHER PHYSICAL CHANGE (SPECIFY) _____

TARGET FORMATION POINT PLEASANT ESTIMATED DEPTH TVD 11,285' TMD: 22,545'

WELL OPERATOR TUG HILL OPERATING, LLC DESIGNATED AGENT DIANNA STAMPER
CT CORPORATION SYSTEM

ADDRESS 1320 SOUTH UNIVERSITY DRIVE, SUITE 500
FORT WORTH, TX 76107 ADDRESS 5400 D BIG TYLER ROAD
CHARLESTON, WV 25313

COUNTY NAME
PERMIT

**GOUDY LEASE
WELL 1S-17HU
366.3537± ACRES**



**Detail "A"
SCALE 1"=1000'**



Number	TAX MAP -PARCEL	SURFACE OWNER	ACRES
S1	D 05-28-12	TH Exploration III, LLC.	20.226
S2	F 05-28-11	Carol A. Martin	24.681
S3	G 05-27-19	Covestro, LLC	33.786
S4	H 05-27-20	Covestro, LLC	93.027
S5	I 05-27-20.1	Appalachian Power Co.	43.973
S6	J 05-27-27	James Andrew & Karen Lynne Richmond	8.9353
S7	L 05-27-25	James Andrew & Karen Lynne Richmond	41.35
S8	12-23-14	Robert F. Rothlisberger	0.27
S9	05-26-19	Eric Jay & Karrel S. Booth	50.0
S10	05-27-23	Robert F. Rothlisberger	35.77
S11	12-01-7.1	Harry Wayman Estate	2.0
S12	P 12-01-04	Robert F. Rothlisberger	6.0
S13	O 12-01-03	Edith Feenerty Harrison & Charles D. Harrison	7.8
S14	N 12-01-02	James A. & Karen L. Richmond	2.7
S15	Q 12-01-05	Irvin L. Hoyt, Jr. & David L. Hoyt	36.8
S16	S 12-01-06	Mona Parsons, et al	52.75
S17	12-01-16	Vivian A. Parsons, et al	5.125
S18	12-01-01	Covestro, LLC	135.0
S19	12-01-1.7	Colombia Gas Transmission, Corp.	0.15
S20	12-23-15	Paul E. & Donna Jo Cain	0.7
S21	12-23-15.1	Robert F. Rothlisberger	0.47
S22	12-23-13	Paul E. & Donna Jo Cain	0.38
S23	05-27-27.2	Paul E. Cain, et ux	0.1767
S24	05-27-27.1	Donald P. Cain	1.645
S25	05-27-27.3	Paul E. Cain, et ux	1.018
S26	K 05-27-28	Covestro, LLC	8.0
S27	12-23-12	Paul E. & Donna Jo Cain	0.37
S28	12-23-11	Covestro, LLC	1.25
S29	12-23-10	Covestro, LLC	1.28
S30	12-23-05	Covestro, LLC	3.69
S31	05-27-40	Covestro, LLC	3.36
S32	12-23-06	Covestro, LLC	0.34
S33	05-27-44	Covestro, LLC	0.21
S34	05-27-43	Covestro, LLC	0.63
S35	05-27-42	Covestro, LLC	0.52
S36	05-27-42.1	Covestro, LLC	0.52
S37	05-27-41	Martha Jean Arrick	0.99
S38	05-27-31.2	Appalachian Power Co.	3.33
S39	05-27-31	Covestro, LLC	16.1
S40	05-27-30	Covestro, LLC	0.371
S41	05-27-31.1	Covestro, LLC	3.0
S42	05-27-32.2	Covestro, LLC	3.95
S43	05-27-29	Covestro, LLC	9.0
S44	05-27-45	Covestro, LLC	0.3627
S45	05-27-32	Covestro, LLC	33.53
S46	05-27-03	Covestro, LLC	1.27
S47	05-27-04	Covestro, LLC	2.52
S48	05-27-05	Covestro, LLC	2.52
S49	05-27-06	Covestro, LLC	2.52
S50	05-27-07	Covestro, LLC	2.52
S51	05-27-08	Covestro, LLC	2.52
S52	05-27-09	Covestro, LLC	1.87
S53	05-27-10	Covestro, LLC	0.52
S54	05-27-12	Covestro, LLC	1.0
S55	05-27-13	Covestro, LLC	0.34
S56	05-27-14	Covestro, LLC	0.25
S57	05-27-15	Covestro, LLC	0.47
S58	05-27-16	Covestro, LLC	0.23
S59	05-27-18	Covestro, LLC	0.97
S60	05-27-17	Covestro, LLC	0.88
S61	05-27-19.3	Cemetery	2.0
S62	05-27-02	Covestro, LLC	28.099
S63	05-27-19.2	Wheeling Electric Co.	0.75
S64	05-28-12.2	Covestro, LLC	3.1
S65	05-28-12.3	Covestro, LLC	18.784
S66	05-28-13.1	Air Products & Chemicals, Inc	5.522
S67	E 05-27-19.1	Covestro, LLC	21.267
S68	05-27-11	Covestro, LLC	0.03
S69	A 05-28-13	TH Exploration III, LLC.	81.36



P.S. 708 *David L Jackson*



**TUG HILL
OPERATING**

OPERATOR'S
WELL #: Goudy 1S-17HU
DISTRICT: Franklin
COUNTY: Marshall
STATE: WV
API # 47-051-02196

WELL PLAT
PAGE 2 OF 3
DATE: 3/15/2019
**REVISED DATE:
7/03/2019**

**GOUDY LEASE
WELL 1S-17HU
366.3537± ACRES**

Lease ID	Parcel	Tags	Granor, Lessor, Etc.	Deed	Page
10*14418	5-28-13	A	PPG INDUSTRIES, INC.	878	610
10*27022	5-28-2	B	COVESTRO, LLC	1046	431
10*14418	5-28-1	C	PPG INDUSTRIES, INC.	878	610
10*14418	5-28-12	D	PPG INDUSTRIES, INC.	878	610
10*14658	5-28-12	D	THOMAS WILLIAM ABERSOLD	775	314
10*14659	5-28-12	D	JUDITH LEE ABERSOLD	781	609
10*14493	5-27-19.1	E	BETTY JEAN NEELY	748	468
10*14494	5-27-19.1	E	MARY LOU WILSON	748	471
10*14495	5-27-19.1	E	PATRICIA HARTMAN	752	197
10*14496	5-27-19.1	E	STEPHANIE L. HALL	752	215
10*14497	5-27-19.1	E	CAROL DEEN GARDNER	752	212
10*27022	5-27-19.1	E	COVESTRO, LLC	1046	431
10*14565	5-28-11	F	HARRY LEE GOUDY	670	59
10*14493	5-27-19	G	BETTY JEAN NEELY	748	468
10*14494	5-27-19	G	MARY LOU WILSON	748	471
10*14495	5-27-19	G	PATRICIA HARTMAN	752	197
10*14496	5-27-19	G	STEPHANIE L. HALL	752	215
10*14497	5-27-19	G	CAROL DEEN GARDNER	752	212
10*27022	5-27-19	G	COVESTRO, LLC	1046	431
10*14493	5-27-20	H	BETTY JEAN NEELY	748	468
10*14494	5-27-20	H	MARY LOU WILSON	748	471
10*14495	5-27-20	H	PATRICIA HARTMAN	752	197
10*14496	5-27-20	H	STEPHANIE L. HALL	752	215
10*14497	5-27-20	H	CAROL DEEN GARDNER	752	212
10*27022	5-27-20	H	COVESTRO, LLC	1046	431
10*14493	5-27-20.1	I	BETTY JEAN NEELY	748	468
10*14494	5-27-20.1	I	MARY LOU WILSON	748	471
10*14495	5-27-20.1	I	PATRICIA HARTMAN	752	197
10*14496	5-27-20.1	I	STEPHANIE L. HALL	752	215
10*14497	5-27-20.1	I	CAROL DEEN GARDNER	752	212
10*14499	5-27-20.1	I	UNION CARBIDE CORPORATION	815	221
10*14505	5-27-27	J	JAMES ANDREW & KAREN RICHMOND	752	447
10*14493	5-27-28	K	BETTY JEAN NEELY	748	468
10*14494	5-27-28	K	MARY LOU WILSON	748	471
10*14495	5-27-28	K	PATRICIA HARTMAN	752	197
10*14496	5-27-28	K	STEPHANIE L. HALL	752	215
10*14497	5-27-28	K	CAROL DEEN GARDNER	752	212
10*27022	5-27-28	K	COVESTRO, LLC	1046	431
10*14505	5-27-25	L	JAMES ANDREW & KAREN RICHMOND	752	447
10*27022	5-27-26	M	COVESTRO, LLC	1046	431
10*15074	12-1-2	N	SCOTT E RALBUSKY	129A	212
10*15091	12-1-3	O	EDITH F & CHARLES D HARRISON	168A	863
10*23502	12-1-4	P	ROBERT F ROTHLSBERGER	210A	801
10*15075	12-1-5	Q	BARBARA P MAZER AS TRSTEE OF THE BARBARA MAZER TRST UNDER AGMT DTD APR 17 2013	129A	693
10*15076	12-1-5	Q	EDWARD PENNINGTON	130A	979
10*15079	12-1-5	Q	JAMES K. HALL	132A	704
10*18122	12-1-5	Q	ANNE L HALL AND RICHARD S WURST	187A	626
10*18175	12-1-5	Q	STONE HILL MINERALS HOLDINGS LLC	188A	791
10*18177	12-1-5	Q	STONE HILL MINERALS HOLDINGS LLC	188A	793
10*18233	12-1-5	Q	SUSAN G HALL	188A	429
10*18286	12-1-5	Q	ELIZABETH H HALL	188A	431
10*19511	12-1-7	R	CORT D ACKER	195A	168
10*24538	12-1-7	R	BRC MINERALS, LP	103A	320
10*18376	12-1-6	S	VICTORIA K MCCLINTOCK	189A	492
10*18377	12-1-6	S	TERRY W GILBERT	189A	494
10*18378	12-1-6	S	CARL J GILBERT SR AND LAURA A GILBERT	189A	496
10*18817	12-1-6	S	JUDITH R WHITE AND FRANKIE D WHITE	192A	518
10*19682	12-1-6	S	NEIL D PATTERSON JR & THERESA PATTERSON	195A	279
10*19998	12-1-6	S	MALISSA D PATTERSON AS AIF FOR CLARK ELWOOD PATTERSON	196A	577
10*24538	12-1-6	S	BRC MINERALS, LP	103A	320
10*22580	12-1-17	T	JAMES H PARSONS JR	209A	265
10*23524	12-1-17	T	HAMMETT LAND & MINERALS LLC SAMUEL C HAMMETT MANAGING MEMBER	210A	807
10*23525	12-1-17	T	HAMMETT LAND & MINERALS LLC SAMUEL C HAMMETT MANAGING MEMBER	210A	809
10*23906	12-1-17	T	JOHN M PARSONS & ANTOINETTE L COSTANTINO	214A	675
10*24090	12-1-17	T	VIVIAN A PARSONS	216A	371
10*24317	12-1-17	T	ROY C PARSONS	218a	480
10*25450	12-1-17	T	MURIEL A MILLER	222A	465
10*25644	12-1-17	T	JOHN P SNYDER	222A	434
10*26612	12-1-17	T	DOROTHY JOANNA SNYDER HAAS	224A	549

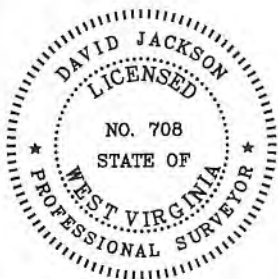

P.S. 708

David L Jackson



**TUG HILL
OPERATING**

OPERATOR'S
WELL #: Goudy 1S-17HU
DISTRICT: Franklin
COUNTY: Marshall
STATE: WV
API # 47-051-02196

WELL PLAT
PAGE 3 OF 3
DATE: 03/15/2019
**REVISED DATE:
07/03/2019**

PROPOSED GOUDY 1S-17HU

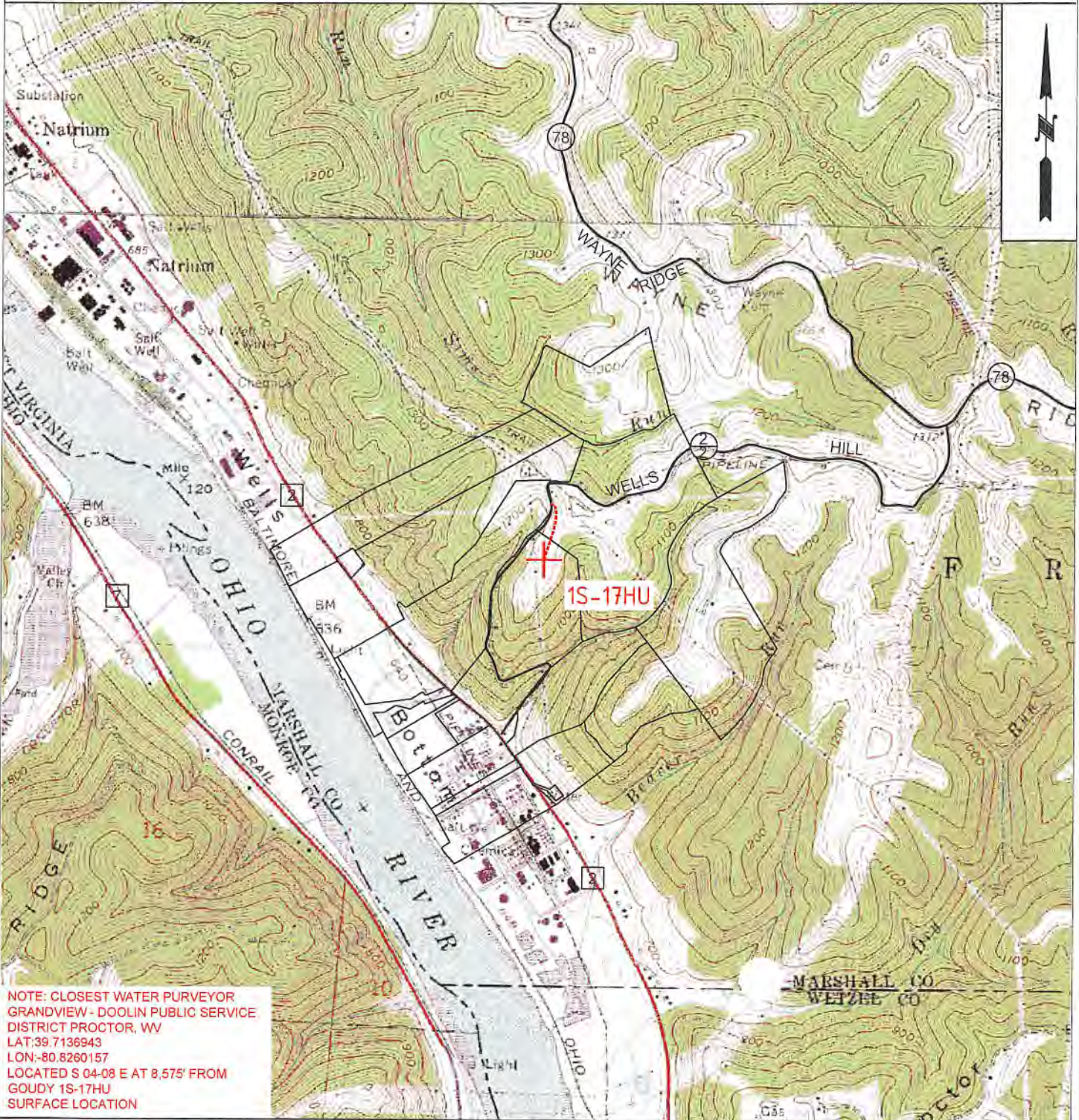

NOTE: CLOSEST WATER PURVEYOR
GRANDVIEW - DOOLIN PUBLIC SERVICE
DISTRICT PROCTOR, WV
LAT: 39.7136943
LON: -80.8260157
LOCATED S 04-08 E AT 8.575' FROM
GOUDY 1S-17HU
SURFACE LOCATION

 TUG HILL OPERATING	OPERATOR	494510851	TOPO SECTION	LEASE NAME
	TUG HILL OPERATING, LLC 380 SOUTHPOINTE BLVD SUITE 200 CANONSBURG, PA 15317		NEW MARTINSVILLE 7.5'	GOUDY
	SCALE:		DATE:	
	1" = 2000'		DATE: 01/25/2019	

**INFORMATION SUPPLIED UNDER WEST VIRGINIA CODE
Chapter 22, Article 6A, Section 5(a)(5)
IN LIEU OF FILING LEASE(S) AND OTHER CONTINUING CONTRACT(S)**

Under the oath required to make the verification on page 1 of this Notice and Application, I depose and say that I am the person who signed the Notice and Application for the Applicant, and that –

- (1) the tract of land is the same tract described in this Application, partly or wholly depicted in the accompanying plat, and described in the Construction and Reclamation Plan;
- (2) the parties and recordation data (if recorded) for lease(s) or other continuing contract(s) by which the Applicant claims the right to extract, produce or market the oil or gas are as follows:

Lease Name or Number	Grantor, Lessor, etc.	Grantee, Lessee, etc.	Royalty	Book/Page
-------------------------	-----------------------	-----------------------	---------	-----------

*See attached pages

**Acknowledgement of Possible Permitting/Approval
In Addition to the Office of Oil and Gas**

The permit applicant for the proposed well work addressed in this application hereby acknowledges the possibility of the need for permits and/or approvals from local, state, or federal entities in addition to the DEP, Office of Oil and Gas, including but not limited to the following:

- WV Division of Water and Waste Management
- WV Division of Natural Resources WV Division of Highways
- U.S. Army Corps of Engineers
- U.S. Fish and Wildlife Service
- County Floodplain Coordinator

The applicant further acknowledges that any Office of Oil and Gas permit in no way overrides, replaces, or nullifies the need for other permits/approvals that may be necessary and further affirms that all needed permits/approvals should be acquired from the appropriate authority before the affected activity is initiated.

Well Operator: Tug Hill Operating, LLC

By: Amy L. Miller 

Its: Permitting Specialist - Appalachia Region

Lease ID	Parcel	Tags	Granor, Lessor, Etc.	Grantee, Lessee, ETC.	Royalty	Deed Book/Page	Assignment	Assignment	Assignment	Assignment	Assignment	Assignment	Assignment	Assignment	Assignment	Assignment	Assignment		
10*14418	5-28-13	A	PGI INDUSTRIES, INC.	GASTAR EXPLORATION INC	1/8+	878	610	N/A	N/A	N/A	N/A	N/A	N/A	N/A	Gastar Exploration Inc to Athium Marcellus I LLC:	35/144	Gastar Exploration Inc to Athium Marcellus I LLC:	36/9	Memorandum of Operating Agreement between TH Exploration LLC and Athium Marcellus I LLC & TH Exploration II LLC: 34/277
10*27022	5-28-2	B	COVESTRO, LLC	TH EXPLORATION LLC	1/8+	1046	431	N/A	N/A	N/A	N/A	N/A	N/A	N/A	N/A	N/A	N/A	N/A	Memorandum of Operating Agreement between TH Exploration LLC and Athium Marcellus I LLC & TH Exploration II LLC: 34/277
10*14418	5-28-1	C	PGI INDUSTRIES, INC.	GASTAR EXPLORATION INC	1/8+	878	610	N/A	N/A	N/A	N/A	N/A	N/A	N/A	N/A	N/A	N/A	N/A	Memorandum of Operating Agreement between TH Exploration LLC and Athium Marcellus I LLC & TH Exploration II LLC: 34/277
10*14418	5-28-12	D	PGI INDUSTRIES, INC.	GASTAR EXPLORATION INC	1/8+	878	610	N/A	N/A	N/A	N/A	N/A	N/A	N/A	N/A	N/A	N/A	N/A	Memorandum of Operating Agreement between TH Exploration LLC and Athium Marcellus I LLC & TH Exploration II LLC: 34/277
10*14658	5-28-12	D	THOMAS WILLIAM ABERSOLD	GASTAR EXPLORATION USA INC	1/8+	775	314	N/A	N/A	N/A	N/A	N/A	N/A	N/A	Gastar Exploration USA Inc to Athium Marcellus I LLC:	28/499	Gastar Exploration USA Inc merged into Gastar Exploration Inc: 21/41	36/9	Memorandum of Operating Agreement between TH Exploration LLC and Athium Marcellus I LLC & TH Exploration II LLC: 34/277
10*14659	5-28-12	D	JUDITH LEE ABERSOLD	GASTAR EXPLORATION USA INC	1/8+	781	609	N/A	N/A	N/A	N/A	N/A	N/A	N/A	Gastar Exploration USA Inc to Athium Marcellus I LLC:	28/499	Gastar Exploration USA Inc merged into Gastar Exploration Inc: 21/41	36/9	Memorandum of Operating Agreement between TH Exploration LLC and Athium Marcellus I LLC & TH Exploration II LLC: 34/277
10*14493	5-27-19.1	E	BETTY JEAN NEEBY	GASTAR EXPLORATION USA INC	1/8+	748	468	N/A	N/A	N/A	N/A	N/A	N/A	N/A	Gastar Exploration USA Inc to Athium Marcellus I LLC:	26/639	Gastar Exploration USA Inc merged into Gastar Exploration Inc: 21/41	36/9	Memorandum of Operating Agreement between TH Exploration LLC and Athium Marcellus I LLC & TH Exploration II LLC: 34/277
10*14494	5-27-19.1	E	MARY LOU WILSON	GASTAR EXPLORATION USA INC	1/8+	748	471	N/A	N/A	N/A	N/A	N/A	N/A	N/A	Gastar Exploration USA Inc to Athium Marcellus I LLC:	26/639	Gastar Exploration USA Inc merged into Gastar Exploration Inc: 21/41	36/9	Memorandum of Operating Agreement between TH Exploration LLC and Athium Marcellus I LLC & TH Exploration II LLC: 34/277
10*14495	5-27-19.1	E	PATRICIA HARTMAN	GASTAR EXPLORATION USA INC	1/8+	752	197	N/A	N/A	N/A	N/A	N/A	N/A	N/A	Gastar Exploration USA Inc to Athium Marcellus I LLC:	26/639	Gastar Exploration USA Inc merged into Gastar Exploration Inc: 21/41	36/9	Memorandum of Operating Agreement between TH Exploration LLC and Athium Marcellus I LLC & TH Exploration II LLC: 34/277
10*14496	5-27-19.1	E	STEPHANIE L. HALL	GASTAR EXPLORATION USA INC	1/8+	752	215	N/A	N/A	N/A	N/A	N/A	N/A	N/A	Gastar Exploration USA Inc to Athium Marcellus I LLC:	26/639	Gastar Exploration USA Inc merged into Gastar Exploration Inc: 21/41	36/9	Memorandum of Operating Agreement between TH Exploration LLC and Athium Marcellus I LLC & TH Exploration II LLC: 34/277
10*14497	5-27-19.1	E	CAROL DEEN GARDNER	GASTAR EXPLORATION USA INC	1/8+	752	212	N/A	N/A	N/A	N/A	N/A	N/A	N/A	Gastar Exploration USA Inc to Athium Marcellus I LLC:	26/639	Gastar Exploration USA Inc merged into Gastar Exploration Inc: 21/41	36/9	Memorandum of Operating Agreement between TH Exploration LLC and Athium Marcellus I LLC & TH Exploration II LLC: 34/277
10*27022	5-27-19.1	E	COVESTRO, LLC	TH EXPLORATION LLC	1/8+	1046	431	N/A	N/A	N/A	N/A	N/A	N/A	N/A	N/A	N/A	N/A	N/A	Memorandum of Operating Agreement between TH Exploration LLC and Athium Marcellus I LLC & TH Exploration II LLC: 34/277
10*14565	5-28-11	F	HARRY LEE GOUDY	CENTRAL MICHIGAN EXPLORATION LLC	1/8+	670	59	N/A	N/A	N/A	N/A	N/A	N/A	N/A	Central Michigan Exploration LLC to Stone Energy Corp: 21/288 & 21/356	27/160	Gastar Exploration USA Inc merged into Gastar Exploration Inc: 21/41	36/9	Memorandum of Operating Agreement between TH Exploration LLC and Athium Marcellus I LLC & TH Exploration II LLC: 34/277

Lease ID	Parcel	Tags	Grantor, Lessor, Etc.	Grantee, Lessee, ETC.	Royalty	Deed Book/Page	Assignment	Assignment	Assignment	Assignment	Assignment	Assignment	Assignment	Assignment	Assignment	Assignment	Assignment				
10*14493	5-27-19	G	BETTY JEAN NEELY	GASTAR EXPLORATION USA INC	1/8+	748	468	N/A	N/A	N/A	N/A	N/A	N/A	N/A	N/A	N/A	Gastar Exploration USA Inc to Atinum Marcellus I LLC: 26/639	Gastar Exploration USA Inc merged into Gastar Exploration Inc: 21/41	Gastar Exploration II LLC: 36/9	Memorandum of Operating Agreement between TH Exploration LLC and Atinum Marcellus I LLC & TH Exploration II LLC: 34/277	
10*14494	5-27-19	G	MARY LOU WILSON	GASTAR EXPLORATION USA INC	1/8+	748	471	N/A	N/A	N/A	N/A	N/A	N/A	N/A	N/A	N/A	Gastar Exploration USA Inc to Atinum Marcellus I LLC: 26/639	Gastar Exploration USA Inc merged into Gastar Exploration Inc: 21/41	Gastar Exploration II LLC: 36/9	Memorandum of Operating Agreement between TH Exploration LLC and Atinum Marcellus I LLC & TH Exploration II LLC: 34/277	
10*14495	5-27-19	G	PATRICIA HARTMAN	GASTAR EXPLORATION USA INC	1/8+	752	197	N/A	N/A	N/A	N/A	N/A	N/A	N/A	N/A	N/A	Gastar Exploration USA Inc to Atinum Marcellus I LLC: 26/639	Gastar Exploration USA Inc merged into Gastar Exploration Inc: 21/41	Gastar Exploration II LLC: 36/9	Memorandum of Operating Agreement between TH Exploration LLC and Atinum Marcellus I LLC & TH Exploration II LLC: 34/277	
10*14496	5-27-19	G	STEPHANIE L. HALL	GASTAR EXPLORATION USA INC	1/8+	752	215	N/A	N/A	N/A	N/A	N/A	N/A	N/A	N/A	N/A	Gastar Exploration USA Inc to Atinum Marcellus I LLC: 26/639	Gastar Exploration USA Inc merged into Gastar Exploration Inc: 21/41	Gastar Exploration II LLC: 36/9	Memorandum of Operating Agreement between TH Exploration LLC and Atinum Marcellus I LLC & TH Exploration II LLC: 34/277	
10*14497	5-27-19	G	CAROL DEEN GARDNER	GASTAR EXPLORATION USA INC	1/8+	752	212	N/A	N/A	N/A	N/A	N/A	N/A	N/A	N/A	N/A	Gastar Exploration USA Inc to Atinum Marcellus I LLC: 26/639	Gastar Exploration USA Inc merged into Gastar Exploration Inc: 21/41	Gastar Exploration II LLC: 36/9	Memorandum of Operating Agreement between TH Exploration LLC and Atinum Marcellus I LLC & TH Exploration II LLC: 34/277	
10*27022	5-27-19	G	COVESTRO, LLC	TH EXPLORATION LLC	1/8+	1046	431	N/A	N/A	N/A	N/A	N/A	N/A	N/A	N/A	N/A	N/A	N/A	N/A	N/A	
10*14493	5-27-20	H	BETTY JEAN NEELY	GASTAR EXPLORATION USA INC	1/8+	748	468	N/A	N/A	N/A	N/A	N/A	N/A	N/A	N/A	N/A	N/A	Gastar Exploration USA Inc to Atinum Marcellus I LLC: 26/639	Gastar Exploration USA Inc merged into Gastar Exploration Inc: 21/41	Gastar Exploration II LLC: 36/9	Memorandum of Operating Agreement between TH Exploration LLC and Atinum Marcellus I LLC & TH Exploration II LLC: 34/277
10*14494	5-27-20	H	MARY LOU WILSON	GASTAR EXPLORATION USA INC	1/8+	748	471	N/A	N/A	N/A	N/A	N/A	N/A	N/A	N/A	N/A	N/A	Gastar Exploration USA Inc to Atinum Marcellus I LLC: 26/639	Gastar Exploration USA Inc merged into Gastar Exploration Inc: 21/41	Gastar Exploration II LLC: 36/9	Memorandum of Operating Agreement between TH Exploration LLC and Atinum Marcellus I LLC & TH Exploration II LLC: 34/277
10*14495	5-27-20	H	PATRICIA HARTMAN	GASTAR EXPLORATION USA INC	1/8+	752	197	N/A	N/A	N/A	N/A	N/A	N/A	N/A	N/A	N/A	N/A	Gastar Exploration USA Inc to Atinum Marcellus I LLC: 26/639	Gastar Exploration USA Inc merged into Gastar Exploration Inc: 21/41	Gastar Exploration II LLC: 36/9	Memorandum of Operating Agreement between TH Exploration LLC and Atinum Marcellus I LLC & TH Exploration II LLC: 34/277
10*14496	5-27-20	H	STEPHANIE L. HALL	GASTAR EXPLORATION USA INC	1/8+	752	215	N/A	N/A	N/A	N/A	N/A	N/A	N/A	N/A	N/A	N/A	Gastar Exploration USA Inc to Atinum Marcellus I LLC: 26/639	Gastar Exploration USA Inc merged into Gastar Exploration Inc: 21/41	Gastar Exploration II LLC: 36/9	Memorandum of Operating Agreement between TH Exploration LLC and Atinum Marcellus I LLC & TH Exploration II LLC: 34/277
10*14497	5-27-20	H	CAROL DEEN GARDNER	GASTAR EXPLORATION USA INC	1/8+	752	212	N/A	N/A	N/A	N/A	N/A	N/A	N/A	N/A	N/A	N/A	Gastar Exploration USA Inc to Atinum Marcellus I LLC: 26/639	Gastar Exploration USA Inc merged into Gastar Exploration Inc: 21/41	Gastar Exploration II LLC: 36/9	Memorandum of Operating Agreement between TH Exploration LLC and Atinum Marcellus I LLC & TH Exploration II LLC: 34/277
10*27022	5-27-20	H	COVESTRO, LLC	TH EXPLORATION LLC	1/8+	1046	431	N/A	N/A	N/A	N/A	N/A	N/A	N/A	N/A	N/A	N/A	N/A	N/A	N/A	N/A
10*14493	5-27-20.1	I	BETTY JEAN NEELY	GASTAR EXPLORATION USA INC	1/8+	748	468	N/A	N/A	N/A	N/A	N/A	N/A	N/A	N/A	N/A	N/A	Gastar Exploration USA Inc to Atinum Marcellus I LLC: 26/639	Gastar Exploration USA Inc merged into Gastar Exploration Inc: 21/41	Gastar Exploration II LLC: 36/9	Memorandum of Operating Agreement between TH Exploration LLC and Atinum Marcellus I LLC & TH Exploration II LLC: 34/277

Lease ID	Parcel	Tags	Grantor, Lessor, Etc.	Grantee, Lessee, ETC.	Royalty	Deed Book/Page	Assignment	Assignment	Assignment	Assignment	Assignment	Assignment	Assignment	Assignment		
10*14505	5-27-25	L	JAMES ANDREW & KAREN RICHMOND	GASTAR EXPLORATION USA INC	1/8+	752	447	N/A	N/A	N/A	N/A	N/A	Gastar Exploration USA Inc to Athnum Marcellus I LLC: 26/639	Gastar Exploration USA Inc merged into Gastar Exploration Inc: 21/41	Gastar Exploration Inc to Athnum Marcellus I LLC & TH Exploration II LLC: 36/9	Memorandum of Operating Agreement between TH Exploration LLC and Athnum Marcellus I LLC & TH Exploration II LLC: 34/277
10*27022	5-27-26	M	COVESTRO, LLC	TH EXPLORATION LLC	1/8+	1046	431	N/A	N/A	N/A	N/A	N/A	N/A	N/A	N/A	Memorandum of Operating Agreement between TH Exploration LLC and Athnum Marcellus I LLC & TH Exploration II LLC: 34/277
10*15074	12-1-2	N	SCOTT E RALBUSKY	GASTAR EXPLORATION USA INC	1/8+	129A	212	N/A	N/A	N/A	N/A	N/A	Gastar Exploration USA Inc merged into Gastar Exploration Inc: 13/270	Gastar Exploration USA Inc merged into Gastar Exploration Inc: 13/270	Gastar Exploration Inc to Athnum Marcellus I LLC & TH Exploration II LLC: 173A/431	Memorandum of Operating Agreement between TH Exploration LLC and Athnum Marcellus I LLC & TH Exploration II LLC: 173A/431
10*15091	12-1-3	O	EDITH F & CHARLES D HARRISON	GASTAR EXPLORATION USA INC	1/8+	168A	863	N/A	N/A	N/A	N/A	N/A	Gastar Exploration USA Inc merged into Gastar Exploration Inc: 13/270	Gastar Exploration USA Inc merged into Gastar Exploration Inc: 13/270	Gastar Exploration Inc to Athnum Marcellus I LLC & TH Exploration II LLC: 173A/431	Memorandum of Operating Agreement between TH Exploration LLC and Athnum Marcellus I LLC & TH Exploration II LLC: 173A/431
10*23502	12-1-4	P	ROBERT F KOTHUISBERGER	TH EXPLORATION LLC	1/8+	210A	801	N/A	N/A	N/A	N/A	N/A	Gastar Exploration USA Inc to Athnum Marcellus I LLC: 135A/284	Gastar Exploration USA Inc merged into Gastar Exploration Inc: 13/270	Gastar Exploration Inc to Athnum Marcellus I LLC & TH Exploration II LLC: 173A/431	Memorandum of Operating Agreement between TH Exploration LLC and Athnum Marcellus I LLC & TH Exploration II LLC: 173A/431
10*15075	12-1-5	Q	BARBARA P MAZER AS TRUSTEE OF THE BARBARA MAZER TRST UNDER AGMT DTD APR 17 2013	GASTAR EXPLORATION USA INC	1/8+	129A	693	N/A	N/A	N/A	N/A	N/A	Gastar Exploration USA Inc to Athnum Marcellus I LLC: 135A/284	Gastar Exploration USA Inc merged into Gastar Exploration Inc: 13/270	Gastar Exploration Inc to Athnum Marcellus I LLC & TH Exploration II LLC: 173A/431	Memorandum of Operating Agreement between TH Exploration LLC and Athnum Marcellus I LLC & TH Exploration II LLC: 173A/431
10*15076	12-1-5	Q	EDWARD PENNINGTON	GASTAR EXPLORATION USA INC	1/8+	130A	979	N/A	N/A	N/A	N/A	N/A	Gastar Exploration USA Inc to Athnum Marcellus I LLC: 135A/284	Gastar Exploration USA Inc merged into Gastar Exploration Inc: 13/270	Gastar Exploration Inc to Athnum Marcellus I LLC & TH Exploration II LLC: 173A/431	Memorandum of Operating Agreement between TH Exploration LLC and Athnum Marcellus I LLC & TH Exploration II LLC: 173A/431
10*15079	12-1-5	Q	JAMES K. HALL	GASTAR EXPLORATION USA INC	1/8+	132A	704	N/A	N/A	N/A	N/A	N/A	Gastar Exploration USA Inc to Athnum Marcellus I LLC: 135A/284	Gastar Exploration USA Inc merged into Gastar Exploration Inc: 13/270	Gastar Exploration Inc to Athnum Marcellus I LLC & TH Exploration II LLC: 173A/431	Memorandum of Operating Agreement between TH Exploration LLC and Athnum Marcellus I LLC & TH Exploration II LLC: 173A/431
10*18122	12-1-5	Q	ANNE L HALL AND RICHARD S WURST	TH EXPLORATION LLC	1/8+	187A	626	N/A	N/A	N/A	N/A	N/A	Gastar Exploration USA Inc to Athnum Marcellus I LLC: 135A/284	Gastar Exploration USA Inc merged into Gastar Exploration Inc: 13/270	Gastar Exploration Inc to Athnum Marcellus I LLC & TH Exploration II LLC: 173A/431	Memorandum of Operating Agreement between TH Exploration LLC and Athnum Marcellus I LLC & TH Exploration II LLC: 173A/431
10*18175	12-1-5	Q	STONE HILL MINERALS HOLDINGS LLC	TH EXPLORATION LLC	1/8+	188A	791	N/A	N/A	N/A	N/A	N/A	Gastar Exploration USA Inc to Athnum Marcellus I LLC: 135A/284	Gastar Exploration USA Inc merged into Gastar Exploration Inc: 13/270	Gastar Exploration Inc to Athnum Marcellus I LLC & TH Exploration II LLC: 173A/431	Memorandum of Operating Agreement between TH Exploration LLC and Athnum Marcellus I LLC & TH Exploration II LLC: 173A/431
10*18177	12-1-5	Q	STONE HILL MINERALS HOLDINGS LLC	TH EXPLORATION LLC	1/8+	188A	793	N/A	N/A	N/A	N/A	N/A	Gastar Exploration USA Inc to Athnum Marcellus I LLC: 135A/284	Gastar Exploration USA Inc merged into Gastar Exploration Inc: 13/270	Gastar Exploration Inc to Athnum Marcellus I LLC & TH Exploration II LLC: 173A/431	Memorandum of Operating Agreement between TH Exploration LLC and Athnum Marcellus I LLC & TH Exploration II LLC: 173A/431
10*18233	12-1-5	Q	SUSAN G HALL	TH EXPLORATION LLC	1/8+	188A	429	N/A	N/A	N/A	N/A	N/A	Gastar Exploration USA Inc to Athnum Marcellus I LLC: 135A/284	Gastar Exploration USA Inc merged into Gastar Exploration Inc: 13/270	Gastar Exploration Inc to Athnum Marcellus I LLC & TH Exploration II LLC: 173A/431	Memorandum of Operating Agreement between TH Exploration LLC and Athnum Marcellus I LLC & TH Exploration II LLC: 173A/431
10*18286	12-1-5	Q	ELIZABETH H HALL	TH EXPLORATION LLC	1/8+	188A	431	N/A	N/A	N/A	N/A	N/A	Gastar Exploration USA Inc to Athnum Marcellus I LLC: 135A/284	Gastar Exploration USA Inc merged into Gastar Exploration Inc: 13/270	Gastar Exploration Inc to Athnum Marcellus I LLC & TH Exploration II LLC: 173A/431	Memorandum of Operating Agreement between TH Exploration LLC and Athnum Marcellus I LLC & TH Exploration II LLC: 173A/431
10*19511	12-1-7	R	CORR D ACKER	TH EXPLORATION LLC	1/8+	195A	168	N/A	N/A	N/A	N/A	N/A	Gastar Exploration USA Inc to Athnum Marcellus I LLC: 135A/284	Gastar Exploration USA Inc merged into Gastar Exploration Inc: 13/270	Gastar Exploration Inc to Athnum Marcellus I LLC & TH Exploration II LLC: 173A/431	Memorandum of Operating Agreement between TH Exploration LLC and Athnum Marcellus I LLC & TH Exploration II LLC: 173A/431
10*24538	12-1-7	R	BRC MINERALS, LP	BRC WORKING INTEREST COMPANY LLC	1/8+	103A	320	BRC Working Interest Company LLC to Chesapeake Appalachia LLC: 103A/470	Chesapeake Appalachia LLC to Statoil USA Onshore Properties Inc: 120A/109	Chesapeake Appalachia LLC to SWN Production Company: 157A/540	Statoil USA Onshore Properties Inc to SWN Exchange Titleholder LLC: 158A/801	SWN Exchange Titleholder LLC merged into SWN Production Company: 13/296	SWN Production Company to Antero Exchange Properties LLC: 177A/533	Statoil USA Onshore Properties Inc to Antero Exchange Properties LLC: 177A/738	Antero Exchange Properties LLC merged into Antero Resources Corporation: 13/311	Antero Resources Corporation to TH Exploration LLC: 228A/761
10*18376	12-1-6	S	VICTORIA K MCCLEINTOCK	TH EXPLORATION LLC	1/8+	189A	492	N/A	N/A	N/A	N/A	N/A	Gastar Exploration USA Inc to Athnum Marcellus I LLC: 135A/284	Gastar Exploration USA Inc merged into Gastar Exploration Inc: 13/270	Gastar Exploration Inc to Athnum Marcellus I LLC & TH Exploration II LLC: 173A/431	Memorandum of Operating Agreement between TH Exploration LLC and Athnum Marcellus I LLC & TH Exploration II LLC: 173A/431
10*18377	12-1-6	S	TERRY W GILBERT	TH EXPLORATION LLC	1/8+	189A	494	N/A	N/A	N/A	N/A	N/A	Gastar Exploration USA Inc to Athnum Marcellus I LLC: 135A/284	Gastar Exploration USA Inc merged into Gastar Exploration Inc: 13/270	Gastar Exploration Inc to Athnum Marcellus I LLC & TH Exploration II LLC: 173A/431	Memorandum of Operating Agreement between TH Exploration LLC and Athnum Marcellus I LLC & TH Exploration II LLC: 173A/431
10*18378	12-1-6	S	CARL J GILBERT SR AND LAURA A	TH EXPLORATION LLC	1/8+	189A	496	N/A	N/A	N/A	N/A	N/A	Gastar Exploration USA Inc to Athnum Marcellus I LLC: 135A/284	Gastar Exploration USA Inc merged into Gastar Exploration Inc: 13/270	Gastar Exploration Inc to Athnum Marcellus I LLC & TH Exploration II LLC: 173A/431	Memorandum of Operating Agreement between TH Exploration LLC and Athnum Marcellus I LLC & TH Exploration II LLC: 173A/431
10*18817	12-1-6	S	JUDITH R WHITE AND FRANKIE D WHITE	TH EXPLORATION LLC	1/8+	192A	518	N/A	N/A	N/A	N/A	N/A	Gastar Exploration USA Inc to Athnum Marcellus I LLC: 135A/284	Gastar Exploration USA Inc merged into Gastar Exploration Inc: 13/270	Gastar Exploration Inc to Athnum Marcellus I LLC & TH Exploration II LLC: 173A/431	Memorandum of Operating Agreement between TH Exploration LLC and Athnum Marcellus I LLC & TH Exploration II LLC: 173A/431
10*19682	12-1-6	S	NEIL D PATTERSON JR & TERESA PATTERSON	TH EXPLORATION LLC	1/8+	195A	279	N/A	N/A	N/A	N/A	N/A	Gastar Exploration USA Inc to Athnum Marcellus I LLC: 135A/284	Gastar Exploration USA Inc merged into Gastar Exploration Inc: 13/270	Gastar Exploration Inc to Athnum Marcellus I LLC & TH Exploration II LLC: 173A/431	Memorandum of Operating Agreement between TH Exploration LLC and Athnum Marcellus I LLC & TH Exploration II LLC: 173A/431
10*19998	12-1-6	S	MALISSA D PATTERSON AS AIF FOR CLARK ELWOOD PATTERSON	TH EXPLORATION LLC	1/8+	196A	577	N/A	N/A	N/A	N/A	N/A	Gastar Exploration USA Inc to Athnum Marcellus I LLC: 135A/284	Gastar Exploration USA Inc merged into Gastar Exploration Inc: 13/270	Gastar Exploration Inc to Athnum Marcellus I LLC & TH Exploration II LLC: 173A/431	Memorandum of Operating Agreement between TH Exploration LLC and Athnum Marcellus I LLC & TH Exploration II LLC: 173A/431
10*24538	12-1-6	S	BRC MINERALS, LP	BRC WORKING INTEREST COMPANY LLC	1/8+	103A	320	BRC Working Interest Company LLC to Chesapeake Appalachia LLC: 103A/470	Chesapeake Appalachia LLC to Statoil USA Onshore Properties Inc: 120A/109	Chesapeake Appalachia LLC to SWN Production Company: 157A/540	Statoil USA Onshore Properties Inc to SWN Exchange Titleholder LLC: 158A/801	SWN Exchange Titleholder LLC merged into SWN Production Company: 13/296	SWN Production Company to Antero Exchange Properties LLC: 177A/533	Statoil USA Onshore Properties Inc to Antero Exchange Properties LLC: 177A/738	Antero Exchange Properties LLC merged into Antero Resources Corporation: 13/311	Antero Resources Corporation to TH Exploration LLC: 228A/761
10*22580	12-1-17	T	JAMES H PARSONS JR	TH EXPLORATION LLC	1/8+	209A	265	N/A	N/A	N/A	N/A	N/A	Gastar Exploration USA Inc to Athnum Marcellus I LLC: 135A/284	Gastar Exploration USA Inc merged into Gastar Exploration Inc: 13/270	Gastar Exploration Inc to Athnum Marcellus I LLC & TH Exploration II LLC: 173A/431	Memorandum of Operating Agreement between TH Exploration LLC and Athnum Marcellus I LLC & TH Exploration II LLC: 173A/431

MEMORANDUM OF OPERATING AGREEMENT AND FINANCING STATEMENT

This Memorandum of Operating Agreement and Financing Statement (hereinafter referred to as "Memorandum") is executed to be effective concurrently with that certain Operating Agreement (the "Operating Agreement") by and between TH Exploration, LLC, as Operator, and Atinum Marcellus I LLC and TH Exploration II, LLC, as Non-Operators, covering, among other things, the development and production of crude oil, natural gas and associated substances from the leases (hereinafter called the "Contract Area") described on Exhibit "A", Exhibit "A-1" and Exhibit "A-2" attached hereto and owned by Operator and Non-Operator in the respective percentages of shares indicated on Exhibit "A" to the Operating Agreement.

The Operating Agreement contains an Accounting Procedure, along with provisions giving the parties hereto mutual liens and security interests where one or more parties hereto are or may become Debtors to one or more other parties hereto. This Memorandum incorporates by reference all of the terms and conditions of the Operating Agreement, including but not limited to the lien and security interest provisions.

The purpose of this Memorandum is to place third parties on notice of the Operating Agreement, and to secure and perfect the mutual liens and security interests of the parties hereto.

The Operating Agreement specifically provides and the parties do hereby confirm and agree that:

1. The Operator shall conduct and direct and have full control of all operations on the Contract Area as permitted and required by, and within the limits of, the Operating Agreement.
2. The liability of the parties under the Operating Agreement shall be several, not joint or collective. Each party shall be responsible only for its obligations and shall be liable only for its proportionate share of costs.
3. Each Non-Operator grants to Operator a lien upon its oil and gas rights, oil and gas leases and mineral interests in the Contract Area, and a security interest in its share of oil and/or gas when extracted and its interest in all fixtures, inventory, personal property and equipment located on or used on the Contract Area and in all its contract rights and receivables related thereto and arising therefrom to secure payment of its present and future share of costs and expenses, together with interest thereon at the rate provided in the Accounting Procedure referred to above. To the extent that Operator has a security interest under the Uniform Commercial Code ("Code") of the state or states in which the Contract Area is located, Operator without prejudice and in addition to all other legal, equitable and contractual remedies which are expressly reserved, shall be entitled to exercise the rights and remedies of a secured party under the Code. The bringing of a suit and the obtaining of judgment by Operator for the secured indebtedness shall not be deemed an election of remedies or otherwise affect the rights or security interests for the payment thereof.
4. The Operator grants to Non-Operator a lien and security interest equivalent to that granted to Operator as described in Paragraph 3 above, to secure payment by Operator of its own share of costs and expenses when due.

As reflected above, either or both Operator and Non-Operator may become Debtors if they default in their payment obligations under the terms of the Operating Agreement. On default, the non-defaulting party(ies) will be considered secured party(ies).

Wetzel County
Clerk
Instrument: 260482
07/11/2018 @ 01:25:35 PM
OIL AND GAS
Book 218A @ Page 761
Pages Recorded 6
Recording Cost \$ 12.00

PARTIAL ASSIGNMENT AND CONVEYANCE OF OIL AND GAS LEASE

STATE OF WEST VIRGINIA)
) §
COUNTY OF WETZEL)

This Partial Assignment and Conveyance of Oil and Gas Leases (this "Assignment"), dated effective as of December 7, 2018 at 7:00 a.m. Central Time (the "Effective Time"), is made by Antero Resources Corporation, a Delaware corporation, whose address is 1615 Wynkoop Street, Denver, CO 80202 ("Assignor"), to TH Exploration, LLC, a Texas limited liability company, whose address is 1320 S. University Drive, Suite 500, Fort Worth, TX 76107 ("Assignee"). Assignor and Assignee are sometimes referred to herein together as the "Parties" and individually as a "Party."

WHEREAS, Assignor owns an undivided working interest in the Leases (as defined below).

WHEREAS, Assignor desires to assign to Assignee, and Assignee desires to accept such assignment of, the Leasehold Rights (as defined below), as more particularly described in this Assignment.

NOW, THEREFORE, for and in consideration of Ten Dollars (\$10.00) and other valuable consideration, the receipt and sufficiency of which is hereby acknowledged:

Assignor does hereby GRANT, BARGAIN, TRANSFER, ASSIGN and CONVEY to Assignee 100% of Assignor's right, title and interest in and to the oil and gas leases described in more detail on Exhibit A, less and except those certain portions, if any, retained by Assignor as described on Exhibit A, (such oil and gas leases, the "Leases", and 100% of Assignor's collective right, title and interest in and to the Leases less an except those portions, if any, retained by Assignor, the "Leasehold Rights").

This Assignment is further made subject to the following:

1. **Assignment Subject to Trade Agreement.** This Assignment is made in accordance with and is subject to the terms, covenants and conditions contained in that certain Trade Agreement, dated October 12, 2018 by and between Assignor and Assignee (as the same may be amended from time to time, the "Trade Agreement"). In the event of a conflict between the provisions of the Trade Agreement and this Assignment, the provisions of the Trade Agreement shall control. The execution and delivery of this Assignment by Assignor, and the execution and acceptance of this Assignment by Assignee, shall not operate to release or impair any surviving rights or obligations of Assignor or Assignee under the Trade Agreement. Capitalized terms used but not otherwise defined in this Assignment shall have the respective meanings given to such terms in the Trade Agreement.
2. **Assumption of Liabilities.** Subject to the terms of the Trade Agreement, effective as of the Effective Time, Assignee hereby acknowledges, assumes, and agrees to assume, pay, perform, fulfill and discharge the Tug Hill Assumed Liabilities.
3. **Special Warranty of Title.** Assignor (a) hereby warrants, and shall defend, title to the Leasehold Rights unto Assignee and its successors in interest against every person whomsoever lawfully claiming, or to claim the same or any part thereof by, through or under Assignor or its Affiliates, but not otherwise, subject to the Permitted Encumbrances and (b) hereby subrogates Assignee to all covenants and warranties of title by third persons (other than Assignor and its Affiliates) heretofore given or made to Assignor or its predecessors in title or Affiliates in respect of any of the Leasehold Rights.

AFFIDAVIT

COPY

STATE OF TEXAS §
§ SS
COUNTY OF TARRANT §

On this 18th day of October, 2016, before me, the undersigned authority, personally appeared David D. Kalish ("Affiant") who being first duly sworn under oath, deposes and saith:

1. TH Exploration, LLC, TH Exploration II, LLC and TH Exploration III, LLC are wholly owned subsidiaries of THQ Appalachia I, LLC.
2. Tug Hill Operating, LLC provides oil and gas operations services to THQ Appalachia I, LLC under an Operating Services Agreement dated July 23, 2014.
3. David D. Kalish, the Affiant, is the Vice President of Tug Hill Operating, LLC, THQ Appalachia I, LLC, TH Exploration, LLC, TH Exploration II, LLC and TH Exploration III, LLC, and;
3. Tug Hill Operating, LLC is authorized to operate and maintain the assets owned by THQ Appalachia I, LLC, including, as referenced above, TH Exploration, LLC, TH Exploration II, LLC, and TH Exploration III, LLC, including oil and gas leases, wells, pipelines, surface facilities, and other all other assets that support the business of THQ Appalachia I, LLC, and;
4. Specifically, Tug Hill Operating, LLC is authorized to submit and obtain well work permits and carry out all activities pursuant to such work permits for assets owned by TH Exploration, LLC, TH Exploration II, LLC, TH Exploration III, LLC.

RECEIVED
Office of Oil and Gas

MAR 21 2019

WV Department of
Environmental Protection

FURTHER, AFFIANT SAITH NOT.

IN WITNESS WHEREOF, we have hereunto set our hands and seals this 18th day of October, 2016.

David D. Kalish
Affiant: David D. Kalish

JURAT

Jan Pest
MARSHALL County 03:44:28 PM
Instrument No 1416299
Date Recorded 10/19/2016
Document Type MIS
Pages Recorded 1
Book-Page 28-62
Recording Fee \$5.00
Additional \$5.00

STATE OF TEXAS §
§ SS
COUNTY OF TARRANT §

Sworn and subscribed to (or affirmed) before me on this, the 18th day of October, 2016, by David D. Kalish

IN WITNESS WHEREOF, I hereunto set my hand and official seal.

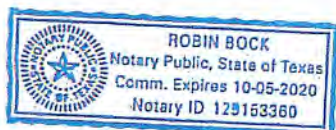

My Commission Expires: 10-05-2020
Signature/Notary Public: Robin Bock
Name/Notary Public (Print): Robin Bock

Jan Post
MARSHALL County 01:22:38 PM
Instrument No 1407489
Date Recorded 04/27/2016
Document Type ASB
Pages Recorded 77
Book Page 36-9
Recording Fee \$77.00
Additional \$13.00

WHEN RECORDED RETURN TO:
TH Exploration II, LLC
1320 South University Drive, Suite 500
Fort Worth, Texas 76107
Attn: David Kalish

Execution Version

ASSIGNMENT AND BILL OF SALE

STATE OF WV

§
§
§

KNOW ALL MEN BY THESE PRESENTS:

COUNTY OF MARSHALL

THIS ASSIGNMENT AND BILL OF SALE (this "Assignment"), dated April 7, 2016, but effective as of 7:00 A.M. Houston time on January 1, 2016 (the "Effective Time"), is between Gasar Exploration Inc., a Delaware corporation, whose address is 1331 Lamar Street, Suite 650 Houston, Texas 77010 ("Assignor"), and TH Exploration II, LLC, a Texas limited liability company, whose address is 1320 South University Drive, Suite 500, Fort Worth, Texas 76107 ("Assignee"). Assignor and Assignee are each, individually, referred to herein as a "Party" and, collectively, as the "Parties".

Capitalized terms used but not defined herein shall have the respective meanings set forth in that certain Purchase and Sale Agreement (the "Purchase Agreement"), dated as of February 19, 2016, by and between Assignor and Assignee (as successor-in-interest).

Section 1. Assignment. The conveyance and assignment herein shall be deemed effective as of the Effective Time.

For Ten Dollars (\$10.00) and other good and valuable consideration (the receipt and sufficiency of which are hereby acknowledged), Assignor does hereby forever GRANT, BARGAIN, SELL, CONVEY, ASSIGN, TRANSFER, SET OVER AND DELIVER unto Assignee, all of Assignor's right, title and interest in and to the following interests and properties (such right, title and interest described in subsections (a) through (b) of this Section 1, less and except the Excluded Assets, collectively, the "Conveyed Interests"):

(a) all oil, gas and/or mineral leases of Assignor, together with any and all other right, title and interest of Assignor in and to the leasehold estates created thereby, including subleases, royalties, overriding royalties, net profits interest, carried interests or similar rights or interests in such leases, and together with all rights, privileges, benefits and powers conferred upon Assignor with respect to the use and occupation of the lands covered thereby that may be necessary, convenient or incidental to the possession and enjoyment of such leases, located in Marshall, Wetzal, Doddridge, Harrison, Lewis, Marion, and Monongalia Counties, West Virginia and Greene, Butler, Fayette, Somerset, and Clearfield Counties, Pennsylvania, including those described on Exhibit A—Part 1 attached hereto (subject to any reservations, limitations or depth restrictions described on Exhibit A—Part 1), (Assignor's interest in such leases and other right, title and interest as so limited, the "Leases");

(b) all rights and interests in, under or derived from all unitization agreements in effect with respect to any of the Leases and the units created thereby, including those described

US 4080690

RECEIVED
Office of Oil and Gas

MAR 21 2019

WV Department of
Environmental Protection

DPS
6000 TOWN CENTER BLVD STE 145
CANDLERBURG PA 15317-5870

Wetzel County
Carol S Haight, Clerk
Instrument 260482
12/11/2018 @ 01:23:35 PM
OIL AND GAS
Book 218A @ Page 755
Pages Recorded 6
Recording Cost \$ 12.00

PARTIAL ASSIGNMENT AND CONVEYANCE OF OIL AND GAS LEASE

STATE OF WEST VIRGINIA)
) §
COUNTY OF WETZEL)

This Partial Assignment and Conveyance of Oil and Gas Leases (this "Assignment"), dated effective as of December 7, 2018 at 7:00 a.m. Central Time (the "Effective Time"), is made by Antero Resources Corporation, a Delaware corporation, whose address is 1615 Wynkoop Street, Denver, CO 80202 ("Assignor"), to TH Exploration, LLC, a Texas limited liability company, whose address is 1320 S. University Drive, Suite 500, Fort Worth, TX 76107 ("Assignee"). Assignor and Assignee are sometimes referred to herein together as the "Parties" and individually as a "Party."

WHEREAS, Assignor owns an undivided working interest in the Leases (as defined below).

WHEREAS, Assignor desires to assign to Assignee, and Assignee desires to accept such assignment of, the Leasehold Rights (as defined below), as more particularly described in this Assignment.

NOW, THEREFORE, for and in consideration of Ten Dollars (\$10.00) and other valuable consideration, the receipt and sufficiency of which is hereby acknowledged:

Assignor does hereby GRANT, BARGAIN, TRANSFER, ASSIGN and CONVEY to Assignee 100% of Assignor's right, title and interest in and to the oil and gas leases described in more detail on Exhibit A, less and except those certain portions, if any, retained by Assignor as described on Exhibit A, (such oil and gas leases, the "Leases", and 100% of Assignor's collective right, title and interest in and to the Leases less an except those portions, if any, retained by Assignor, the "Leasehold Rights").

This Assignment is further made subject to the following:

1. **Assignment Subject to Trade Agreement.** This Assignment is made in accordance with and is subject to the terms, covenants and conditions contained in that certain Trade Agreement, dated October 12, 2018 by and between Assignor and Assignee (as the same may be amended from time to time, the "Trade Agreement"). In the event of a conflict between the provisions of the Trade Agreement and this Assignment, the provisions of the Trade Agreement shall control. The execution and delivery of this Assignment by Assignor, and the execution and acceptance of this Assignment by Assignee, shall not operate to release or impair any surviving rights or obligations of Assignor or Assignee under the Trade Agreement. Capitalized terms used but not otherwise defined in this Assignment shall have the respective meanings given to such terms in the Trade Agreement.
2. **Assumption of Liabilities.** Subject to the terms of the Trade Agreement, effective as of the Effective Time, Assignee hereby acknowledges, assumes, and agrees to assume, pay, perform, fulfill and discharge the Tug Hill Assumed Liabilities.
3. **Special Warranty of Title.** Assignor (a) hereby warrants, and shall defend, title to the Leasehold Rights unto Assignee and its successors in interest against every person whomsoever lawfully claiming, or to claim the same or any part thereof by, through or under Assignor or its Affiliates, but not otherwise, subject to the Permitted Encumbrances and (b) hereby subrogates Assignee to all covenants and warranties of title by third persons (other than Assignor and its Affiliates) heretofore given or made to Assignor or its predecessors in title or Affiliates in respect of any of the Leasehold Rights.

RECEIVED
Office of Oil and Gas
MAR 21 2019
WV Department of
Environmental Protection



March 15, 2019

WV Department of Environmental Protection
Office of Oil & Gas
601 57th Street, SE
Charleston, WV 25304
Attention: Laura Adkins

RE: Goudy 1S-17HU

Subject: Marshall County Route 80 Road Crossing Letter

Dear Laura:

Tug Hill Operating, LLC (THO) hereby submits this letter as confirmation that THO has obtained the right to drill, extract and produce the minerals under Marshall County Route 80 in the area reflected on the Goudy 1S-17HU well plat. THO has conducted a full title search in the relevant Court House to confirm its ownership under said County Routes and is not currently aware of any recorded document that would suggest an ownership other than THO.

If your office has any questions or concerns regarding the contents of this letter, please do not hesitate to contact me directly at 304-376-0111, or by email at amiller@tug-hilop.com.

Sincerely,

A handwritten signature in blue ink that reads "Amy Miller".

Amy Miller
Permit Specialist – Appalachia Region
Cell 304-376-0111
Email: amiller@tug-hilop.com

RECEIVED
Office of Oil and Gas

MAR 21 2019

WV Department of
Environmental Protection

WW-6AC
(1/12)

**STATE OF WEST VIRGINIA
DEPARTMENT OF ENVIRONMENTAL PROTECTION, OFFICE OF OIL AND GAS
NOTICE CERTIFICATION**

Date of Notice Certification: 03/15/2019

API No. 47-051

Operator's Well No. Goudy 1S-17HU

Well Pad Name: Goudy

Notice has been given:

Pursuant to the provisions in West Virginia Code § 22-6A, the Operator has provided the required parties with the Notice Forms listed below for the tract of land as follows:

State: <u>West Virginia</u>	UTM NAD 83 Easting: <u>514,681.25</u>
County: <u>Marshall</u>	UTM NAD 83 Northing: <u>4,398,597.84</u>
District: <u>Franklin</u>	Public Road Access: <u>Wells Hill Road</u>
Quadrangle: <u>New Martinsville 7.5'</u>	Generally used farm name: <u>TH Exploration III, LLC</u>
Watershed: <u>French Creek - Ohio River (HUC 10)</u>	

Pursuant to West Virginia Code § 22-6A-7(b), every permit application filed under this section shall be on a form as may be prescribed by the secretary, shall be verified and shall contain the following information: (14) A certification from the operator that (i) it has provided the owners of the surface described in subdivisions (1), (2) and (4), subsection (b), section ten of this article, the information required by subsections (b) and (c), section sixteen of this article; (ii) that the requirement was deemed satisfied as a result of giving the surface owner notice of entry to survey pursuant to subsection (a), section ten of this article six-a; or (iii) the notice requirements of subsection (b), section sixteen of this article were waived in writing by the surface owner; and Pursuant to West Virginia Code § 22-6A-11(b), the applicant shall tender proof of and certify to the secretary that the notice requirements of section ten of this article have been completed by the applicant.

<p>Pursuant to West Virginia Code § 22-6A, the Operator has attached proof to this Notice Certification that the Operator has properly served the required parties with the following:</p> <p>*PLEASE CHECK ALL THAT APPLY</p> <p><input type="checkbox"/> 1. NOTICE OF SEISMIC ACTIVITY or <input checked="" type="checkbox"/> NOTICE NOT REQUIRED BECAUSE NO SEISMIC ACTIVITY WAS CONDUCTED</p> <p><input checked="" type="checkbox"/> 2. NOTICE OF ENTRY FOR PLAT SURVEY or <input type="checkbox"/> NO PLAT SURVEY WAS CONDUCTED</p> <p><input type="checkbox"/> 3. NOTICE OF INTENT TO DRILL or <input checked="" type="checkbox"/> NOTICE NOT REQUIRED BECAUSE NOTICE OF ENTRY FOR PLAT SURVEY WAS CONDUCTED or</p> <p style="padding-left: 40px;"><input type="checkbox"/> WRITTEN WAIVER BY SURFACE OWNER (PLEASE ATTACH)</p> <p><input checked="" type="checkbox"/> 4. NOTICE OF PLANNED OPERATION</p> <p><input checked="" type="checkbox"/> 5. PUBLIC NOTICE</p> <p><input checked="" type="checkbox"/> 6. NOTICE OF APPLICATION</p>	<p>OOG OFFICE USE ONLY</p> <p><input type="checkbox"/> RECEIVED/ NOT REQUIRED</p> <p><input type="checkbox"/> RECEIVED</p> <p><input type="checkbox"/> RECEIVED/ NOT REQUIRED</p> <p><input type="checkbox"/> RECEIVED</p> <p><input type="checkbox"/> RECEIVED</p> <p><input type="checkbox"/> RECEIVED</p>
<p>RECEIVED Office of Oil and Gas MAR 21 2019</p>	

WV Department of
Environmental Protection

Required Attachments:

The Operator shall attach to this Notice Certification Form all Notice Forms and Certifications of Notice that have been provided to the required parties and/or any associated written waivers. For the Public Notice, the operator shall attach a copy of the Class II Legal Advertisement with publication date verification or the associated Affidavit of Publication. The attached Notice Forms and Certifications of Notice shall serve as proof that the required parties have been noticed as required under West Virginia Code § 22-6A. Pursuant to West Virginia Code § 22-6A-11(b), the Certification of Notice to the person may be made by affidavit of personal service, the return receipt card or other postal receipt for certified mailing.

Certification of Notice is hereby given:

THEREFORE, I Amy L. Miller, have read and understand the notice requirements within West Virginia Code § 22-6A. I certify that as required under West Virginia Code § 22-6A, I have served the attached copies of the Notice Forms, identified above, to the required parties through personal service, by registered mail or by any method of delivery that requires a receipt or signature confirmation. I certify under penalty of law that I have personally examined and am familiar with the information submitted in this Notice Certification and all attachments, and that based on my inquiry of those individuals immediately responsible for obtaining the information, I believe that the information is true, accurate and complete. I am aware that there are significant penalties for submitting false information, including the possibility of fine and imprisonment.

Well Operator:	<u>Tug Hill Operating, LLC</u>	Address:	<u>380 Southpointe Boulevard, Plaza II, Suite 200</u>
By:	<u>Amy L. Miller <i>Amy Miller</i></u>		<u>Canonsburg, PA 15317</u>
Its:	<u>Permitting Specialist</u>	Facsimile:	<u>724-338-2030</u>
Telephone:	<u>724-749-8388</u>	Email:	<u>amiller@tug-hillop.com</u>

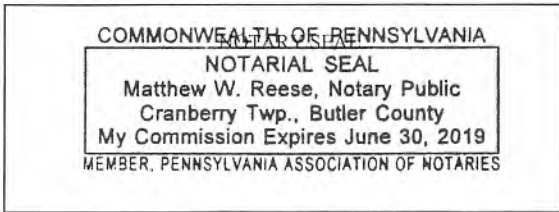

Subscribed and sworn before me this 15 day of MAR. 2019.

Matthew W. Reese Notary Public

My Commission Expires 6-30-2019

Oil and Gas Privacy Notice:

The Office of Oil and Gas processes your personal information, such as name, address and telephone number, as part of our regulatory duties. Your personal information may be disclosed to other State agencies or third parties in the normal course of business or as needed to comply with statutory or regulatory requirements, including Freedom of Information Act requests. Our office will appropriately secure your personal information. If you have any questions about our use or your personal information, please contact DEP's Chief Privacy Officer at deprivacyofficer@wv.gov.

RECEIVED
Office of Oil and Gas

MAR 21 2019

WV Department of
Environmental Protection

WW-6A
(9-13)

API NO. 47- 051 -
OPERATOR WELL NO. Goudy 1S-17HU
Well Pad Name: Goudy

STATE OF WEST VIRGINIA
DEPARTMENT OF ENVIRONMENTAL PROTECTION, OFFICE OF OIL AND GAS
NOTICE OF APPLICATION

Notice Time Requirement: notice shall be provided no later than the **filing date of permit application.**

Date of Notice: 3/13/2019 **Date Permit Application Filed:** 3/15/2019

Notice of:

- PERMIT FOR ANY WELL WORK
- CERTIFICATE OF APPROVAL FOR THE CONSTRUCTION OF AN IMPOUNDMENT OR PIT

Delivery method pursuant to West Virginia Code § 22-6A-10(b)

- PERSONAL SERVICE
- REGISTERED MAIL
- METHOD OF DELIVERY THAT REQUIRES A RECEIPT OR SIGNATURE CONFIRMATION

Pursuant to W. Va. Code § 22-6A-10(b) no later than the filing date of the application, the applicant for a permit for any well work or for a certificate of approval for the construction of an impoundment or pit as required by this article shall deliver, by personal service or by registered mail or by any method of delivery that requires a receipt or signature confirmation, copies of the application, the erosion and sediment control plan required by section seven of this article, and the well plat to each of the following persons: (1) The owners of record of the surface of the tract on which the well is or is proposed to be located; (2) The owners of record of the surface tract or tracts overlying the oil and gas leasehold being developed by the proposed well work, if the surface tract is to be used for roads or other land disturbance as described in the erosion and sediment control plan submitted pursuant to subsection (c), section seven of this article; (3) The coal owner, operator or lessee, in the event the tract of land on which the well proposed to be drilled is located [sic] is known to be underlain by one or more coal seams; (4) The owners of record of the surface tract or tracts overlying the oil and gas leasehold being developed by the proposed well work, if the surface tract is to be used for the placement, construction, enlargement, alteration, repair, removal or abandonment of any impoundment or pit as described in section nine of this article; (5) Any surface owner or water purveyor who is known to the applicant to have a water well, spring or water supply source located within one thousand five hundred feet of the center of the well pad which is used to provide water for consumption by humans or domestic animals; and (6) The operator of any natural gas storage field within which the proposed well work activity is to take place. (c)(1) If more than three tenants in common or other co-owners of interests described in subsection (b) of this section hold interests in the lands, the applicant may serve the documents required upon the person described in the records of the sheriff required to be maintained pursuant to section eight, article one, chapter eleven-a of this code. (2) Notwithstanding any provision of this article to the contrary, notice to a lien holder is not notice to a landowner, unless the lien holder is the landowner. W. Va. Code R. § 35-8-5.7.a requires, in part, that the operator shall also provide the Well Site Safety Plan ("WSSP") to the surface owner and any water purveyor or surface owner subject to notice and water testing as provided in section 15 of this rule.

Application Notice WSSP Notice E&S Plan Notice Well Plat Notice is hereby provided to:

SURFACE OWNER(s)
Name: TH Exploration III, LLC
Address: 1320 S. University Drive, Suite 500
Ft. Worth, TX 76107

Name: COVESTRO, LLC (formerly Bayer Material Science, LLC)
Address: 1 COVESTRO CIRCLE
PITTSBURGH PA 15272

SURFACE OWNER(s) (Road and/or Other Disturbance)
Name: _____
Address: _____

Name: _____
Address: _____

SURFACE OWNER(s) (Impoundments or Pits)
Name: _____
Address: _____

COAL OWNER OR LESSEE
Name: TH Exploration III, LLC
Address: 1320 S. University Drive, Suite 500
Ft. Worth, TX 76107 **See attachment

COAL OPERATOR
Name: _____
Address: _____

SURFACE OWNER OF WATER WELL AND/OR WATER PURVEYOR(s)
Name: _____
Address: _____

OPERATOR OF ANY NATURAL GAS STORAGE FIELD
Name: _____
Address: _____

RECEIVED
Office of Oil and Gas
MAR 21 2019
WV Department of
Environmental Protection

*Please attach additional forms if necessary

Notice is hereby given:

Pursuant to West Virginia Code § 22-6A-10(b), notice is hereby given that the undersigned well operator has applied for a permit for well work or for a certificate of approval for the construction of an impoundment or pit.

This Notice Shall Include:

Pursuant to W. Va. Code § 22-6A-10(b), this notice shall include: (1) copies of the application; (2) the erosion and sediment control plan required by section seven of this article; and (3) the well plat.

Pursuant to W. Va. Code § 22-6A-10(f), this notice shall include: (1) a statement of the time limits for filing written comments; (2) who may file written comments; (3) the name and address of the secretary for the purpose of filing the comments and obtaining additional information; and (4) a statement that the persons may request, at the time of submitting written comments, notice of the permit decision and a list of persons qualified to test water.

Pursuant to W. Va. Code R. § 35-8-5.7.a, the operator shall provide the Well Site Safety Plan to the surface owner and any water purveyor or surface owner subject to notice and water testing as provided in section 15 of this rule.

Pursuant to W. Va. Code R. § 35-8-15.2.c, this notice shall: (1) contain a statement of the surface owner's and water purveyor's right to request sampling and analysis; (2) advise the surface owner and water purveyor of the rebuttable presumption for contamination or deprivation of a fresh water source or supply; advise the surface owner and water purveyor that refusal to allow the operator to conduct a pre-drilling water well test constitutes a method to rebut the presumption of liability; (3) advise the surface owner and water purveyor of his or her independent right to sample and analyze any water supply at his or her own expense; advise the surface owner and water purveyor whether or not the operator will utilize an independent laboratory to analyze any sample; and (4) advise the surface owner and or water purveyor that he or she can obtain from the Chief a list of water testing laboratories in the subject area capable of and qualified to test water supplies in accordance with standard acceptable methods.

Additional information related to horizontal drilling may be obtained from the Secretary, at the WV Department of Environmental Protection headquarters, located at 601 57th Street, SE, Charleston, WV 25304 (304-926-0450) or by visiting www.dep.wv.gov/office-of-oil-and-gas/pages/default.aspx.

RECEIVED
Office of Oil and Gas
MAR 21 2019

Well Location Restrictions

Pursuant to W. Va. Code § 22-6A-12, Wells may not be drilled within two hundred fifty feet measured horizontally from any existing water well or developed spring used for human or domestic animal consumption. The center of well pads may not be located within six hundred twenty-five feet of an occupied dwelling structure, or a building two thousand five hundred square feet or larger used to house or shelter dairy cattle or poultry husbandry. This limitation is applicable to those wells, developed springs, dwellings or agricultural buildings that existed on the date a notice to the surface owner of planned entry for surveying or staking as provided in section ten of this article or a notice of intent to drill a horizontal well as provided in subsection (b), section sixteen of this article was provided, whichever occurs first, and to any dwelling under construction prior to that date. This limitation may be waived by written consent of the surface owner transmitted to the department and recorded in the real property records maintained by the clerk of the county commission for the county in which such property is located. Furthermore, the well operator may be granted a variance by the secretary from these distance restrictions upon submission of a plan which identifies the sufficient measures, facilities or practices to be employed during well site construction, drilling and operations. The variance, if granted, shall include terms and conditions the department requires to ensure the safety and protection of affected persons and property. The terms and conditions may include insurance, bonding and indemnification, as well as technical requirements. (b) No well pad may be prepared or well drilled within one hundred feet measured horizontally from any perennial stream, natural or artificial lake, pond or reservoir, or a wetland, or within three hundred feet of a naturally reproducing trout stream. No well pad may be located within one thousand feet of a surface or ground water intake of a public water supply. The distance from the public water supply as identified by the department shall be measured as follows: (1) For a surface water intake on a lake or reservoir, the distance shall be measured from the boundary of the lake or reservoir. (2) For a surface water intake on a flowing stream, the distance shall be measured from a semicircular radius extending upstream of the surface water intake. (3) For a groundwater source, the distance shall be measured from the wellhead or spring. The department may, in its discretion, waive these distance restrictions upon submission of a plan identifying sufficient measures, facilities or practices to be employed during well site construction, drilling and operations to protect the waters of the state. A waiver, if granted, shall impose any permit conditions as the secretary considers necessary. (c) Notwithstanding the foregoing provisions of this section, nothing contained in this section prevents an operator from conducting the activities permitted or authorized by a Clean Water Act Section 404 permit or other approval from the United States Army Corps of Engineers within any waters of the state or within the restricted areas referenced in this section. (d) The well location restrictions set forth in this section shall not apply to any well on a multiple well pad if at least one of the wells was permitted prior to the effective date of this article. (e) The secretary shall, by December 31, 2012, report to the Legislature on the noise, light, dust and volatile organic compounds generated by the drilling of horizontal wells as they relate to the well location restrictions regarding occupied dwelling structures pursuant to this section. Upon a finding, if any, by the secretary that the well location restrictions regarding occupied dwelling structures are inadequate or otherwise require alteration to address the items

WV Department of
Environmental Protection

examined in the study required by this subsection, the secretary shall have the authority to propose for promulgation legislative rules establishing guidelines and procedures regarding reasonable levels of noise, light, dust and volatile organic compounds relating to drilling horizontal wells, including reasonable means of mitigating such factors, if necessary.

Water Well Testing:

Pursuant to West Virginia Code § 22-6A-10(d), notification shall be made, with respect to surface landowners identified in subsection (b) or water purveyors identified in subdivision (5), subsection (b) of this section, of the opportunity for testing their water well. The operator shall provide an analysis to such surface landowner or water purveyor at their request.

Water Testing Laboratories:

Pursuant to West Virginia Code § 22-6A-10(i), persons entitled to notice pursuant to subsection (b) of this section may contact the department to ascertain the names and locations of water testing laboratories in the subject area capable and qualified to test water supplies in accordance with standard accepted methods. In compiling that list of names the department shall consult with the state Bureau for Public Health and local health departments. A surface owner and water purveyor has an independent right to sample and analyze any water supply at his or her own expense. The laboratory utilized by the operator shall be approved by the agency as being certified and capable of performing sample analyses in accordance with this section.

Rebuttable Presumption for Contamination or Deprivation of a Fresh Water Source or Supply:

W. Va. Code § 22-6A-18 requires that (b) unless rebutted by one of the defenses established in subsection (c) of this section, in any action for contamination or deprivation of a fresh water source or supply within one thousand five hundred feet of the center of the well pad for horizontal well, there is a rebuttable presumption that the drilling and the oil or gas well or either was the proximate cause of the contamination or deprivation of the fresh water source or supply. (c) In order to rebut the presumption of liability established in subsection (b) of this section, the operator must prove by a preponderance of the evidence one of the following defenses: (1) The pollution existed prior to the drilling or alteration activity as determined by a predrilling or prealteration water well test. (2) The landowner or water purveyor refused to allow the operator access to the property to conduct a predrilling or prealteration water well test. (3) The water supply is not within one thousand five hundred feet of the well. (4) The pollution occurred more than six months after completion of drilling or alteration activities. (5) The pollution occurred as the result of some cause other than the drilling or alteration activity. (d) Any operator electing to preserve its defenses under subdivision (1), subsection (c) of this section shall retain the services of an independent certified laboratory to conduct the predrilling or prealteration water well test. A copy of the results of the test shall be submitted to the department and the surface owner or water purveyor in a manner prescribed by the secretary. (e) Any operator shall replace the water supply of an owner of interest in real property who obtains all or part of that owner's supply of water for domestic, agricultural, industrial or other legitimate use from an underground or surface source with a comparable water supply where the secretary determines that the water supply has been affected by contamination, diminution or interruption proximately caused by the oil or gas operation, unless waived in writing by that owner. (f) The secretary may order the operator conducting the oil or gas operation to: (1) Provide an emergency drinking water supply within twenty-four hours; (2) Provide temporary water supply within seventy-two hours; (3) Within thirty days begin activities to establish a permanent water supply or submit a proposal to the secretary outlining the measures and timetables to be used in establishing a permanent supply. The total time in providing a permanent water supply may not exceed two years. If the operator demonstrates that providing a permanent replacement water supply cannot be completed within two years, the secretary may extend the time frame on case-by-case basis; and (4) Pay all reasonable costs incurred by the real property owner in securing a water supply. (g) A person as described in subsection (b) of this section aggrieved under the provisions of subsections (b), (e) or (f) of this section may seek relief in court... (i) Notwithstanding the denial of the operator of responsibility for the damage to the real property owner's water supply or the status of any appeal on determination of liability for the damage to the real property owner's water supply, the operator may not discontinue providing the required water service until authorized to do so by the secretary or a court of competent jurisdiction.

Written Comment:

Pursuant to West Virginia Code § 22-6A-11(a), all persons described in subsection (b), section ten of this article may file written comments with the secretary as to the location or construction of the applicant's proposed well work within thirty days after the application is filed with the secretary. All persons described in West Virginia Code § 22-6A-10(b) may file written comments as to the location or construction of the applicant's proposed well work to the Secretary at:

Chief, Office of Oil and Gas
Department of Environmental Protection
601 57th St. SE
Charleston, WV 25304
(304) 926-0450

Such persons may request, at the time of submitting written comments, notice of the permit decision and a list of persons qualified to test water. **NOTE: YOU ARE NOT REQUIRED TO FILE ANY COMMENT.**

WW-6A
(8-13)

API NO. 47- 051 -
OPERATOR WELL NO. Goudy 1S-17HU
Well Pad Name: Goudy

Time Limits and Methods for Filing Comments.

The law requires these materials to be served on or before the date the operator files its Application. You have **THIRTY (30) DAYS** after the filing date to file your comments. Comments must be filed in person or received in the mail by the Chief's office by the time stated above. You may call the Chief's office to be sure of the date. Check with your postmaster to ensure adequate delivery time or to arrange special expedited handling. If you have been contacted by the well operator and you have signed a "voluntary statement of no objection" to the planned work described in these materials, then the permit may be issued at any time.

Pursuant to West Virginia Code § 22-6A-11(c)(2), Any objections of the affected coal operators and coal seam owners and lessees shall be addressed through the processes and procedures that exist under sections fifteen, seventeen and forty, article six of this chapter, as applicable and as incorporated into this article by section five of this article. The written comments filed by the parties entitled to notice under subdivisions (1), (2), (4), (5) and (6), subsection (b), section ten of this article shall be considered by the secretary in the permit issuance process, but the parties are not entitled to participate in the processes and proceedings that exist under sections fifteen, seventeen or forty, article six of this chapter, as applicable and as incorporated into this article by section five of this article.

Comment Requirements

Your comments must be in writing and include your name, address and telephone number, the well operator's name and well number and the approximate location of the proposed well site including district and county from the application. You may add other documents, such as sketches, maps or photographs to support your comments.

Disclaimer: All comments received will be placed on our web site <http://www.dep.wv.gov/oil-and-gas/Horizontal-Permits/Pages/default.aspx> and the applicant will automatically be forwarded an email notice that such comments have been submitted. The applicant will be expected to provide a response to comments submitted by any surface owner, water purveyor or natural gas storage operator noticed within the application.

Permit Denial or Condition

The Chief has the power to deny or condition a well work permit. Pursuant to West Virginia Code § 22-6A-8(d), the permit may not be issued or be conditioned, including conditions with respect to the location of the well and access roads prior to issuance if the director determines that:

- (1) The proposed well work will constitute a hazard to the safety of persons;
- (2) The plan for soil erosion and sediment control is not adequate or effective;
- (3) Damage would occur to publicly owned lands or resources; or
- (4) The proposed well work fails to protect fresh water sources or supplies.

A permit may also be denied under West Virginia Code § 22-6A-7(k), the secretary shall deny the issuance of a permit if the secretary determines that the applicant has committed a substantial violation of a previously issued permit for a horizontal well, including the applicable erosion and sediment control plan associated with the previously issued permit, or a substantial violation of one or more of the rules promulgated under this article, and in each instance has failed to abate or seek review of the violation within the time prescribed by the secretary pursuant to the provisions of subdivisions (1) and (2), subsection (a), section five of this article and the rules promulgated hereunder, which time may not be unreasonable.

Pursuant to West Virginia Code § 22-6A-10(g), any person entitled to submit written comments to the secretary pursuant to subsection (a), section eleven of this article, shall also be entitled to receive from the secretary a copy of the permit as issued or a copy of the order modifying or denying the permit if the person requests receipt of them as a part of the written comments submitted concerning the permit application. Such persons may request, at the time of submitting written comments, notice of the permit decision and a list of persons qualified to test water.

RECEIVED
MAR 21 2019

WV Department of
Environmental Protection

WW-6A
(8-13)

API NO. 47- 051 -
OPERATOR WELL NO. Goudy 1S-17HU
Well Pad Name: Goudy

Notice is hereby given by:

Well Operator: Tug Hill Operating, LLC
Telephone: 724-749-8388
Email: amiller@tug-hilltop.com *amiller*

Address: 380 Southpointe Boulevard, Plaza II, Suite 200
Canonsburg, PA 15317
Facsimile: 724-838-2030

Oil and Gas Privacy Notice:

The Office of Oil and Gas processes your personal information, such as name, address and telephone number, as part of our regulatory duties. Your personal information may be disclosed to other State agencies or third parties in the normal course of business or as needed to comply with statutory or regulatory requirements, including Freedom of Information Act requests. Our office will appropriately secure your personal information. If you have any questions about our use or your personal information, please contact DEP's Chief Privacy Officer at depprivacyofficer@wv.gov.

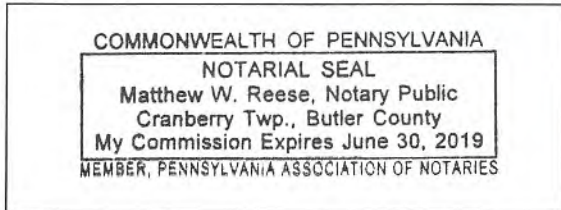

Subscribed and sworn before me this 13 day of Mar, 2019.

Matthew W. Reese

Notary Public

My Commission Expires 6/30/2019

RECEIVED
Office of Oil and Gas

MAR 21 2019

WV Department of
Environmental Protection

Operator Well No.: GOUDY 1S-17HU

**WW-6A Notice of Application
Supplement Page**

COAL OWNER(S):

NAME: APPALACHIAN POWER CO.
ADDRESS: 1 RIVERSIDE PLACE
COLUMBUS, OH 43215 \

NAME: COVESTRO, LLC (FORMERLY BAYER MATERIAL SCIENCE, LLC)
ADDRESS: 1 CONVESTRO CIRCLE
PITTSBURGH, PA 15205 \

RECEIVED
Office of Oil and Gas

MAR 21 2019

WV Department of
Environmental Protection

WW-6A

PROPOSED GOUDY 1S-17HU

SUPPLEMENT PG 1

There appears to be no (0) possible water source within 2,000'.

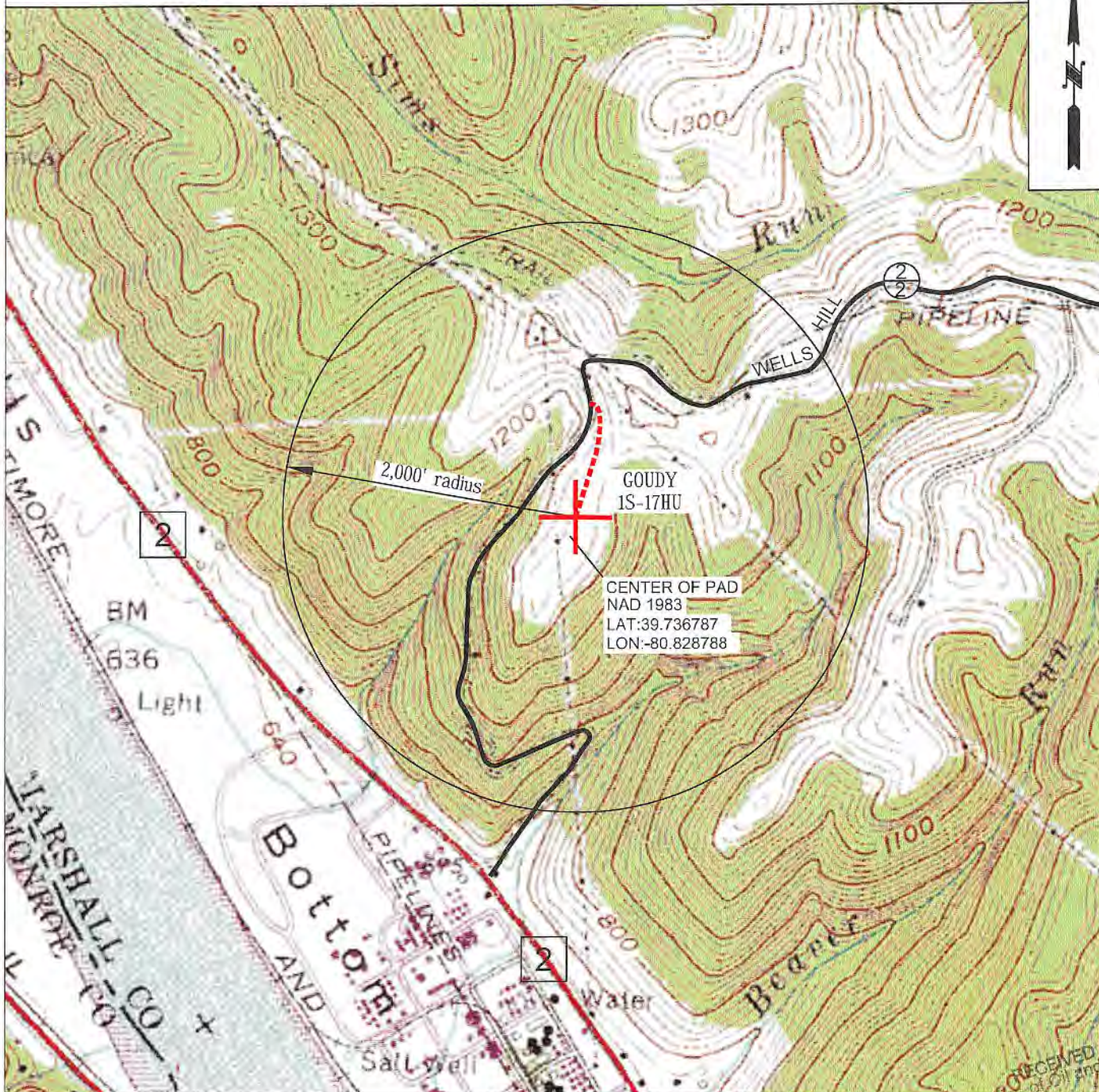

RECEIVED
Office of Oil and Gas

MAR 21 2019

West Virginia Department of
Environmental Protection



OPERATOR	494510851
TUG HILL OPERATING, LLC 380 SOUTHPOINTE BLVD SUITE 200 CANONSBURG, PA 15317	

TOPO SECTION	NEW MARTINSVILLE 7.5'
SCALE:	1" = 1000'

LEASE NAME	GOUDY
DATE:	DATE: 01/25/2019

STATE OF WEST VIRGINIA
DEPARTMENT OF ENVIRONMENTAL PROTECTION, OFFICE OF OIL AND GAS
NOTICE OF ENTRY FOR PLAT SURVEY

Notice Time Requirement: Notice shall be provided at least **SEVEN (7)** days but no more than **FORTY-FIVE (45)** days prior to entry

Date of Notice: 1/8/2019 **Date of Planned Entry:** 1/15/2018

Delivery method pursuant to West Virginia Code § 22-6A-10a

- PERSONAL SERVICE
 REGISTERED MAIL
 METHOD OF DELIVERY THAT REQUIRES A RECEIPT OR SIGNATURE CONFIRMATION

Pursuant to West Virginia Code § 22-6A-10(a), Prior to filing a permit application, the operator shall provide notice of planned entry on to the surface tract to conduct any plat surveys required pursuant to this article. Such notice shall be provided at least seven days but no more than forty-five days prior to such entry to: (1) The surface owner of such tract; (2) to any owner or lessee of coal seams beneath such tract that has filed a declaration pursuant to section thirty-six, article six, chapter twenty-two of this code; and (3) any owner of minerals underlying such tract in the county tax records. The notice shall include a statement that copies of the state Erosion and Sediment Control Manual and the statutes and rules related to oil and gas exploration and production may be obtained from the Secretary, which statement shall include contact information, including the address for a web page on the Secretary's web site, to enable the surface owner to obtain copies from the secretary.

Notice is hereby provided to:

SURFACE OWNER(s)

Name: TH Exploration III, LLC
Address: 1320 S. University Drive, Suite 500
Ft. Worth, TX 76107

Name: COVESTRO, LLC (formerly Bayer Material Science, LLC)
Address: 1 COVESTRO CIRCLE
PITTSBURGH PA 15272

Name: _____
Address: _____

COAL OWNER OR LESSEE

Name: TH Exploration III, LLC
Address: 1320 S. University Drive, Suite 500
Ft. Worth, TX 76107 **SEE ATTACHED

MINERAL OWNER(s)

Name: TH Exploration III, LLC
Address: 1320 S. University Drive, Suite 500
Ft. Worth, TX 76107 **SEE ATTACHED

*please attach additional forms if necessary

Notice is hereby given:

Pursuant to West Virginia Code § 22-6A-10(a), notice is hereby given that the undersigned well operator is planning entry to conduct a plat survey on the tract of land as follows:

State: <u>WEST VIRGINIA</u>	Approx. Latitude & Longitude: <u>39.73678670; -80.82878798</u>
County: <u>MARSHALL</u>	Public Road Access: <u>WELLS HEAD ROAD (ROUTE 22)</u>
District: <u>FRANKLIN</u>	Watershed: <u>(HUC 10) FRENCH CREEK- OHIO RIVER</u>
Quadrangle: <u>NEW MARTINSVILLE</u>	Generally used farm name: <u>PPG INDUSTRIES, INC.</u>

Copies of the state Erosion and Sediment Control Manual and the statutes and rules related to oil and gas exploration and production may be obtained from the Secretary, at the WV Department of Environmental Protection headquarters, located at 601 57th Street, SE, Charleston, WV 25304 (304-926-0450). Copies of such documents or additional information related to horizontal drilling may be obtained from the Secretary by visiting www.dep.wv.gov/oil-and-gas/pages/default.aspx.

RECEIVED
Office of Oil and Gas

MAR 21 2019

Notice is hereby given by:

Well Operator: TUG HILL OPERATING, LLC
Telephone: 724-338-2026
Email: amiller@tug-hillop.com

Address: 380 SOUTHPOINTE BLVD, SOUTHPOINTE PLAZA II, SUITE 200
CANONSBURG, PA 15317
Facsimile: 724-338-2030

Department of Environmental Protection

Oil and Gas Privacy Notice:

The Office of Oil and Gas processes your personal information, such as name, address and telephone number, as part of our regulatory duties. Your personal information may be disclosed to other State agencies or third parties in the normal course of business or as needed to comply with statutory or regulatory requirements, including Freedom of Information Act requests. Our office will appropriately secure your personal information. If you have any questions about our use or your personal information, please contact DEP's Chief Privacy Officer at depprivacyofficer@wv.gov.

**WW-6A Notice of Application
Supplement Page**

COAL OWNER(S):

NAME: APPALACHIAN POWER CO.
ADDRESS: 1 RIVERSIDE PLACE
COLUMBUS, OH 43215

NAME: COVESTRO, LLC (FORMERLY BAYER MATERIAL SCIENCE, LLC)
ADDRESS: 1 COVESTRO CIRCLE
PITTSBURGH, PA 15205

MINERAL OWNER(S):

NAME: COVESTRO, LLC (FORMERLY BAYER MATERIAL SCIENCE, LLC)
ADDRESS: 1 COVESTRO CIRCLE
PITTSBURGH, PA 15205

RECEIVED
Office of Oil and Gas
MAR 21 2019
WV Department of
Environmental Protection

STATE OF WEST VIRGINIA
DEPARTMENT OF ENVIRONMENTAL PROTECTION, OFFICE OF OIL AND GAS
NOTICE OF PLANNED OPERATION

Notice Time Requirement: notice shall be provided no later than the **filing date of permit application.**

Date of Notice: 03/15/2019 **Date Permit Application Filed:** 03/15/2019

Delivery method pursuant to West Virginia Code § 22-6A-16(c)

- CERTIFIED MAIL HAND
RETURN RECEIPT REQUESTED DELIVERY

Pursuant to W. Va. Code § 22-6A-16(c), no later than the date for filing the permit application, an operator shall, by certified mail return receipt requested or hand delivery, give the surface owner whose land will be used for the drilling of a horizontal well notice of the planned operation. The notice required by this subsection shall include: (1) A copy of this code section; (2) The information required to be provided by subsection (b), section ten of this article to a surface owner whose land will be used in conjunction with the drilling of a horizontal well; and (3) A proposed surface use and compensation agreement containing an offer of compensation for damages to the surface affected by oil and gas operations to the extent the damages are compensable under article six-b of this chapter. (d) The notices required by this section shall be given to the surface owner at the address listed in the records of the sheriff at the time of notice.

Notice is hereby provided to the SURFACE OWNER(s)

(at the address listed in the records of the sheriff at the time of notice):

Name: TH Exploration III, LLC
Address: 1320 S. University Drive, suite 500
Fort Worth, TX 76107

Name: COVESTRO, LLC (formerly Bayer Material Science, LLC)
Address: 1 Covestro Circle
Pittsburgh, PA 15272

Notice is hereby given:

Pursuant to West Virginia Code § 22-6A-16(c), notice is hereby given that the undersigned well operator has developed a planned operation on the surface owner's land for the purpose of drilling a horizontal well on the tract of land as follows:

State:	<u>West Virginia</u>	UTM NAD 83	Easting:	<u>514,681.25</u>
County:	<u>Marshall</u>		Northing:	<u>4,398,597.84</u>
District:	<u>Franklin</u>	Public Road Access:	<u>Wells Hill Road</u>	
Quadrangle:	<u>New Martinsville 7.5'</u>	Generally used farm name:	<u>TH Exploration III, LLC</u>	
Watershed:	<u>French Creek - Ohio River</u>			

RECEIVED
Office of Oil and Gas
MAR 21 2019
WV Department of Environmental Protection

This Notice Shall Include:

Pursuant to West Virginia Code § 22-6A-16(c), this notice shall include: (1) A copy of this code section; (2) The information required to be provided by **W. Va. Code § 22-6A-10(b)** to a surface owner whose land will be used in conjunction with the drilling of a horizontal well; and (3) A proposed surface use and compensation agreement containing an offer of compensation for damages to the surface affected by oil and gas operations to the extent the damages are compensable under article six-b of this chapter. Additional information related to horizontal drilling may be obtained from the Secretary, at the WV Department of Environmental Protection headquarters, located at 601 57th Street, SE, Charleston, WV 25304 (304-926-0450) or by visiting www.dep.wv.gov/oil-and-gas/pages/default.aspx.

Well Operator: Tug Hill Operating, LLC
Telephone: 724-749-8388
Email: amiller@tug-hillop.com

Address: 380 Southpointe Boulevard, Plaza II, Suite 300
Canonsburg, PA 15317
Facsimile: 724-338-2030

Oil and Gas Privacy Notice:

The Office of Oil and Gas processes your personal information, such as name, address and telephone number, as part of our regulatory duties. Your personal information may be disclosed to other State agencies or third parties in the normal course of business or as needed to comply with statutory or regulatory requirements, including Freedom of Information Act requests. Our office will appropriately secure your personal information. If you have any questions about our use of your personal information, please contact DEP's Chief Privacy Officer at depprivacyofficer@wv.gov.

4705702196



WEST VIRGINIA DEPARTMENT OF TRANSPORTATION
Division of Highways

1900 Kanawha Boulevard East • Building Five • Room 110
Charleston, West Virginia 25305-0430 • (304) 558-3505

Thomas J. Smith, P. E.
Secretary of Transportation/
Commissioner of Highways

March 15, 2019

Jill M. Newman
Deputy Commissioner

James A. Martin, Chief
Office of Oil and Gas
Department of Environmental Protection
601 57th Street, SE
Charleston, WV 25304

Subject: DOH Permit for the Goudy Well Pad, Marshall County
Goudy 1S-17HU

Dear Mr. Martin,

This well site will be accessed from Permit #06-2012-0518 transferred to Tug Hill Operating for access to the State Road for a well site located off of Marshall County Route 2/2 SLS.

The operator has signed a DISTRICT WIDE OIL AND GAS ROAD MAINTENANCE BONDING AGREEMENT and provided the required Bond. This operator is currently in compliance with the DOH OIL AND GAS POLICY dated October 1, 2018.

Very Truly Yours,

A handwritten signature in blue ink that reads "Gary K. Clayton".

Gary K. Clayton, P.E.
Regional Maintenance Engineer
Central Office O&G Coordinator

RECEIVED
Office of Oil and Gas

MAR 21 2019

WV Department of
Environmental Protection

Cc: Amy Miller
Tug Hill Operating
CH, OM, D-6
File



PLANNED ADDITIVES TO BE USED IN FRACTURING OR STIMULATION

Well No. Goudy 1S-17HU

PRODUCT NAME:	CHEMICAL DESCRIPTION:	PRODUCT USE:	HAZARDOUS COMPONENT:
GBW-20C	Hemicellulase Breaker	Breaker - Water	None
ALPHA 1427		Biocide	Glutaraldehyde – CAS#000111-30-8 Quaternary ammonium chloride CAS# 007173-51-5 Alky dimethyl benzyl ammonium Chloride (C12-16) – CAS#068424-85-1 Ethanol – CAS# 000064-17-5 Water – CAS# 007732-18-5
FRAC SAND	Silica Sand (various Mesh sizes)	Proppant	Crystalline silica (quartz) CAS# 14808-60-7
S-8C, Sand	Silica Sand (100 mesh)	Sand	Silica – CAS# 14808-60-7
GW-3LDF		Gellant - Water	Petroleum Distillate Blend – Proprietary, (Not Associated with Diesel Fuel) Guar gum – CAS# 009000-30-0
FRW-18		Friction Reducer	Hydrotreated light distillate CAS# 064742-47-8
Scaletrol		Scale Inhibitor	Ethylene glycol – CAS# 000107-21-1 Diethylene glycol – CAS# 000111-46-6

RECEIVED
Office of Oil and Gas
MAR 21 2019
WV Department of
Environmental Protection

**WVDEP OOG
ACCEPTED AS-BUILT**
WJL 6/19/2018

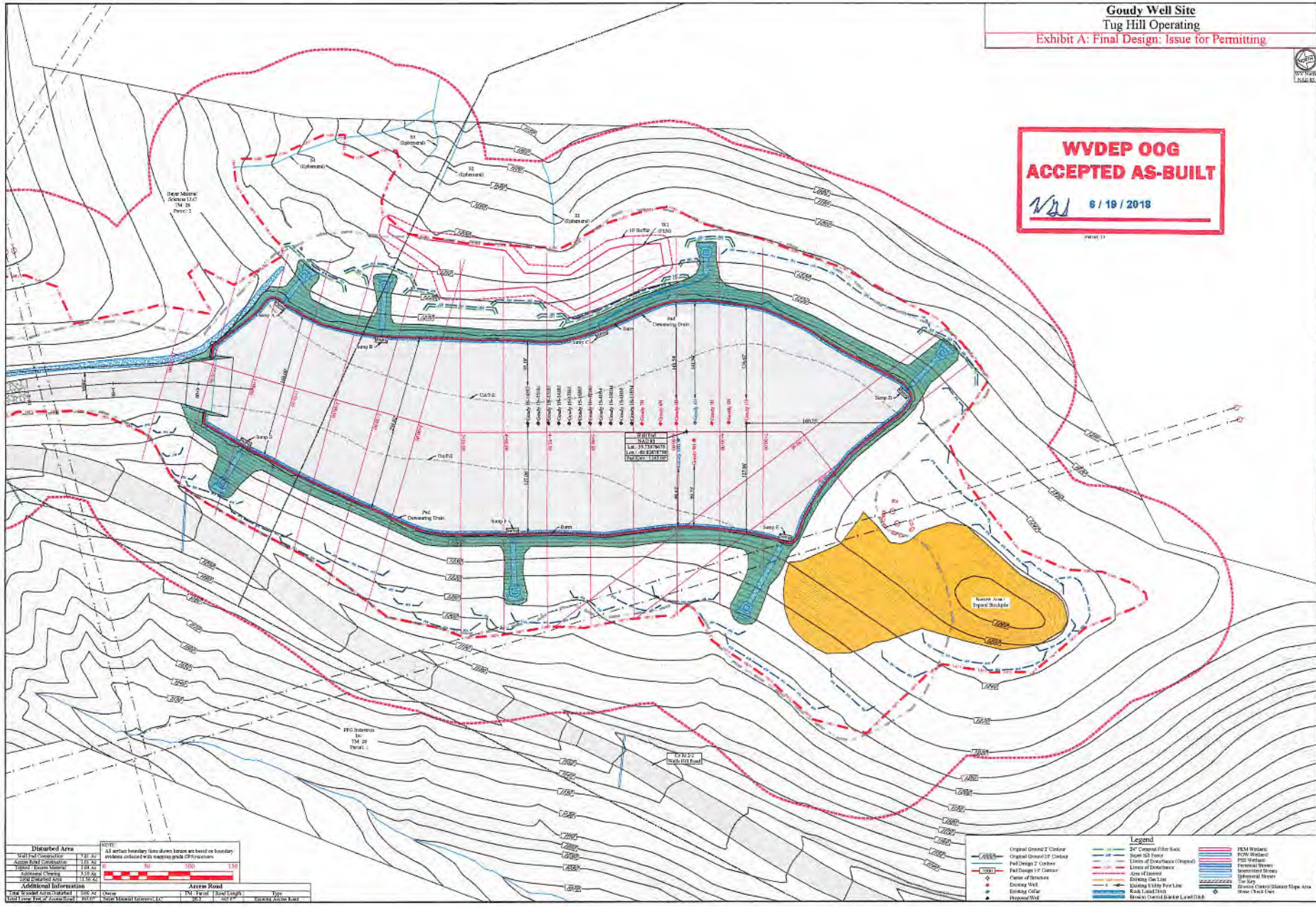

Disturbed Area

Final F20 Contour	1:10' AS
Access Road Construction	1:10' AS
Access Road Maintenance	1:10' AS
Access Road Clearing	1:10' AS
Access Road Paving	1:10' AS

Additional Information

Scale	1" = 100'
North Arrow	North
Project Name	Goudy Well Site
Client	Tug Hill Operating
Design Firm	URS
Sheet No.	10 of 12

Legend

Original Ground 2' Contour	20' Contour Filter Sock	FFC Station
Original Ground 10' Contour	Storm 50' Storm	FFC Station
Final Design 2' Contour	Line of Discharge (Original)	FFC Station
Final Design 10' Contour	Line of Discharge	FFC Station
Point of Structure	Area of Impact	FFC Station
Ditching Well	Existing Utility Pole Line	FFC Station
Existing Catch	Rock Landfill	FFC Station
Proposed 20'	Broken Down Rock Landfill	FFC Station

Scale: 1" = 100'

North Arrow

TUG HILL OPERATING

THIS DOCUMENT PREPARED FOR TUG HILL OPERATING

K+S CONSULTING

Site Plan
Goudy Well Site
Franklin District
Marshall County, WV

Date: 06/19/2018
Scale: As Shown
Designed By: JES
Sheet 10 of 12