



west virginia department of environmental protection

Office of Oil and Gas
601 57th Street, S.E.
Charleston, WV 25304
(304) 926-0450
fax: (304) 926-0452

Austin Caperton, Cabinet Secretary
www.dep.wv.gov

Wednesday, September 30, 2020
PERMIT MODIFICATION APPROVAL
Horizontal 6A / New Drill

TUG HILL OPERATING, LLC
380 SOUTHPOINTE BOULEVARD, PLAZA II
SUITE 200
CANONSBURG, PA 15317

Re: Permit Modification Approval for FITZGERALD S-19HU
47-051-02326-00-00

TUG HILL OPERATING, LLC

The Office of Oil and Gas has reviewed the attached permit modification for the above referenced permit. The attached modification has been approved and well work may begin. Please be reminded that the oil and gas inspector is to be notified twenty-four (24) hours before permitted well work is commenced.

If there are any questions, please feel free to contact me at (304) 926- 0450.

James A. Martin
Chief

A handwritten signature in blue ink, appearing to read 'James A. Martin', is positioned to the right of the typed name and title.

Operator's Well Number: FITZGERALD S-19HU
Farm Name: DANNY AND FRANCES KERNS ESTATE
U.S. WELL NUMBER: 47-051-02326-00-00
Horizontal 6A New Drill
Date Modification Issued: 9/30/2020

Promoting a healthy environment.

18) **CASING AND TUBING PROGRAM**

TYPE	<u>Size (in)</u>	<u>New or Used</u>	<u>Grade</u>	<u>Weight per ft. (lb/ft)</u>	<u>FOOTAGE: For Drilling (ft)</u>	<u>INTERVALS: Left in Well (ft)</u>	<u>CEMENT: Fill-up (Cu. Ft.)/CTS</u>
Conductor							
Fresh Water							
Coal							
Intermediate							
Production							
Tubing							
Liners							

JM

TYPE	<u>Size (in)</u>	<u>Wellbore Diameter (in)</u>	<u>Wall Thickness (in)</u>	<u>Burst Pressure (psi)</u>	<u>Anticipated Max. Internal Pressure (psi)</u>	<u>Cement Type</u>	<u>Cement Yield (cu. ft./k)</u>
Conductor							
Fresh Water							
Coal							
Intermediate							
Production							
Tubing							
Liners							

PACKERS

Kind:				
Sizes:				
Depths Set:				

JM

19) Describe proposed well work, including the drilling and plugging back of any pilot hole:

20) Describe fracturing/stimulating methods in detail, including anticipated max pressure and max rate:

21) Total Area to be disturbed, including roads, stockpile area, pits, etc., (acres): _____

22) Area to be disturbed for well pad only, less access road (acres): _____

23) Describe centralizer placement for each casing string:

24) Describe all cement additives associated with each cement type:

25) Proposed borehole conditioning procedures:

*Note: Attach additional sheets as needed.



WELL NAME: Fitzgerald S-19HU
 STATE: WV COUNTY: Marshall
 DISTRICT: Meade
 DF Elev: 1,293' GL Elev: 1,293'
 TD: 22,323'
 TH Latitude: 39.801177
 TH Longitude: -80.641177
 BH Latitude: 39.78270001
 BH Longitude: -80.63718301

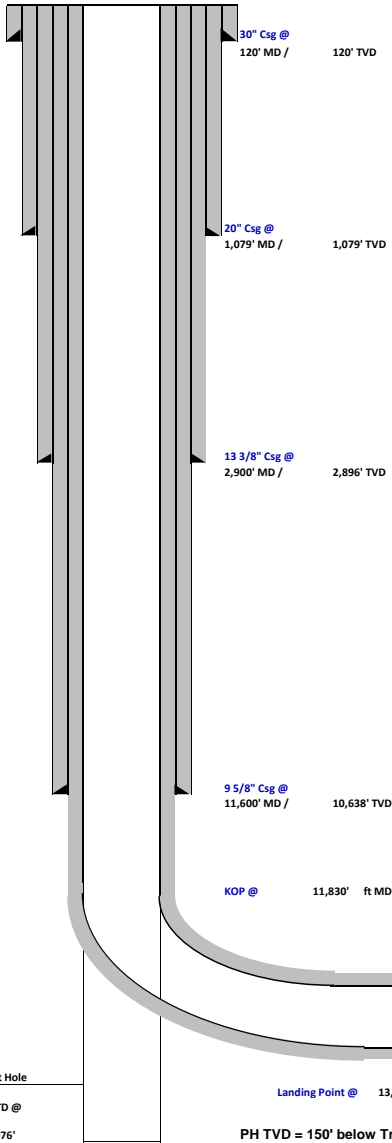

FORMATION TOPS	
Formation	Depth TVD
Deepest Fresh Water	1029'
Sewickley Coal	925'
Pittsburgh Coal	1023'
Big Lime	2,242'
Berea	2,860'
Tully	6,806'
Marcellus	6,919'
Onondaga	6,971'
Salina	7,694'
Lockport	8,703'
Utica	11,525'
Point Pleasant	11,793'
Landing Depth	11,843'
Trenton	11,926'
Pilot Hole TD	12,076'

CASING SUMMARY							
Type	Hole Size (in)	Csg Size (in)	Depth (MD)	Depth (TVD)	Weight (lb/ft)	Grade	Top of Cement
Conductor	36	30	120'	120'	8W	8W	Surface
Surface	26	20	1,079'	1,079'	106.5	J55	Surface
Intermediate 1	17 1/2	13 3/8	2,900'	2,896'	54.5	J55	Surface
Intermediate 2	12 1/4	9 5/8	11,600'	10,638'	47	HPP110	Surface
Production	8 1/2	5 1/2	22,323'	12,002'	23	HCP110	Surface

CEMENT SUMMARY				DRILLING DETAILS	
	Sacks	Class	Density	Fluid Type	Centralizer Notes
Conductor	338	A	15.6	Air	None
Surface	1,868	A	15.6	Air	3 Centralizers at equal distance
Intermediate 1	2,215	A	15	Air	1 Centralizer every other jt
Intermediate 2	3,097	A	14.5	Air	1 Centralizer every other jt
Production	4,673	A	15	Air / SOBM	1 every other joint in lateral; 1 per joint in curve; 1 every other jt to sfc

JZ 9/29/2020

Pilot Hole PH TD @ 12,076'
 Landing Point @ 13,265' MD / 11,843' TVD
 PH TVD = 150' below Trenton Top
 Lateral TD @ 22,323' ft MD
 12,002' ft TVD



Tug Hill Operating, LLC Casing and Cement Program

Fitzgerald S-19HU

Casing

	String	Grade	Bit Size	Depth (Measured)	Cement Fill Up
Conductor	30"	BW	36"	120'	CTS
Surface	20"	J55	26"	1,079'	CTS
Intermediate 1	13 3/8"	J55	17 1/2"	2,900'	CTS
Intermediate 2	9 5/8"	HPP110	12 1/4"	11,600'	CTS
Production	5 1/2"	HCP110	8 1/2"	22,323'	CTS

Cement

Surface: Premium NE-1 + 2% bwoc CaC12 + 46.5% Fresh Water – Surface Cement mixed at 15.6 ppg, Y=1.2

Intermediate 1: Premium NE-1 + 1% bwoc CaC12 + 46.5% Fresh Water – Intermediate Cement mixed at 15.6 ppg, Y=1.2

Intermediate 2: Premium NE-1 + 1% bwoc CaC12 + 46.5% Fresh Water – Intermediate Cement mixed at 15.6 ppg, Y=1.99

Production: 50:50 Poz: Premium NE-1 + .1% bwoc ASA-301 + 60lb/sk ASCA-1 + .35% bwoc BA-10A + .25% bwoc MPA-170, 44 lb sack + .5% bwoc R-3 + .75 gals/100sk FP-13L – Production Cement mixed at 15.2ppg, Y = 1.18



west virginia department of environmental protection

Office of Oil and Gas
601 57th Street, S.E.
Charleston, WV 25304
(304) 926-0450
fax: (304) 926-0452

Austin Caperton, Cabinet Secretary
www.dep.wv.gov

Wednesday, September 30, 2020
PERMIT MODIFICATION APPROVAL
Horizontal 6A / New Drill

TUG HILL OPERATING, LLC
380 SOUTHPOINTE BOULEVARD, PLAZA II
SUITE 200
CANONSBURG, PA 15317

Re: Permit Modification Approval for FITZGERALD S-19HU
47-051-02326-00-00

TUG HILL OPERATING, LLC

The Office of Oil and Gas has reviewed the attached permit modification for the above referenced permit. The attached modification has been approved and well work may begin. Please be reminded that the oil and gas inspector is to be notified twenty-four (24) hours before permitted well work is commenced.

If there are any questions, please feel free to contact me at (304) 926- 0450.

James A. Martin
Chief

A handwritten signature in blue ink, appearing to read 'James A. Martin', is positioned to the right of the typed name and title.

Operator's Well Number: FITZGERALD S-19HU
Farm Name: DANNY AND FRANCES KERNS ESTATE
U.S. WELL NUMBER: 47-051-02326-00-00
Horizontal 6A New Drill
Date Modification Issued: 9/30/2020

Promoting a healthy environment.

STATE OF WEST VIRGINIA
DEPARTMENT OF ENVIRONMENTAL PROTECTION, OFFICE OF OIL AND GAS
WELL WORK PERMIT APPLICATION

1) Well Operator: _____
Operator ID _____ County _____ District _____ Quadrangle _____

2) Operator's Well Number: _____ Well Pad Name: _____

3) Farm Name/Surface Owner: _____ Public Road Access: _____

4) Elevation, current ground: _____ Elevation, proposed post-construction: _____

5) Well Type (a) Gas _____ Oil _____ Underground Storage _____

Other _____

(b) If Gas Shallow _____ Deep _____

Horizontal _____ *JM*

6) Existing Pad: Yes or No _____

7) Proposed Target Formation(s), Depth(s), Anticipated Thickness and Expected Pressure(s):

8) Proposed Total Vertical Depth: _____

9) Formation at Total Vertical Depth: _____

10) Proposed Total Measured Depth: _____

11) Proposed Horizontal Leg Length: _____

12) Approximate Fresh Water Strata Depths: _____

13) Method to Determine Fresh Water Depths: _____

14) Approximate Saltwater Depths: _____

15) Approximate Coal Seam Depths: _____

16) Approximate Depth to Possible Void (coal mine, karst, other): _____

17) Does Proposed well location contain coal seams directly overlying or adjacent to an active mine? Yes _____ No _____

(a) If Yes, provide Mine Info: Name: _____
Depth: _____
Seam: _____
Owner: _____

18) **CASING AND TUBING PROGRAM**

TYPE	Size (in)	New or Used	Grade	Weight per ft. (lb/ft)	FOOTAGE: For Drilling (ft)	INTERVALS: Left in Well (ft)	CEMENT: Fill-up (Cu. Ft.)/CTS
Conductor							
Fresh Water							
Coal							
Intermediate							
Production							
Tubing							
Liners							

JM

TYPE	Size (in)	Wellbore Diameter (in)	Wall Thickness (in)	Burst Pressure (psi)	Anticipated Max. Internal Pressure (psi)	Cement Type	Cement Yield (cu. ft./k)
Conductor							
Fresh Water							
Coal							
Intermediate							
Production							
Tubing							
Liners							

PACKERS

Kind:				
Sizes:				
Depths Set:				

19) Describe proposed well work, including the drilling and plugging back of any pilot hole:

20) Describe fracturing/stimulating methods in detail, including anticipated max pressure and max rate:

21) Total Area to be disturbed, including roads, stockpile area, pits, etc., (acres): _____

22) Area to be disturbed for well pad only, less access road (acres): _____

23) Describe centralizer placement for each casing string:

24) Describe all cement additives associated with each cement type:

25) Proposed borehole conditioning procedures:

*Note: Attach additional sheets as needed.



WELL NAME: Fitzgerald S-19HU
 STATE: WV COUNTY: Marshall
 DISTRICT: Meade
 DF Elev: 1,293' GL Elev: 1,293'
 TD: 22,323'
 TH Latitude: 39.801177
 TH Longitude: -80.641177
 BH Latitude: 39.78270001
 BH Longitude: -80.63718301

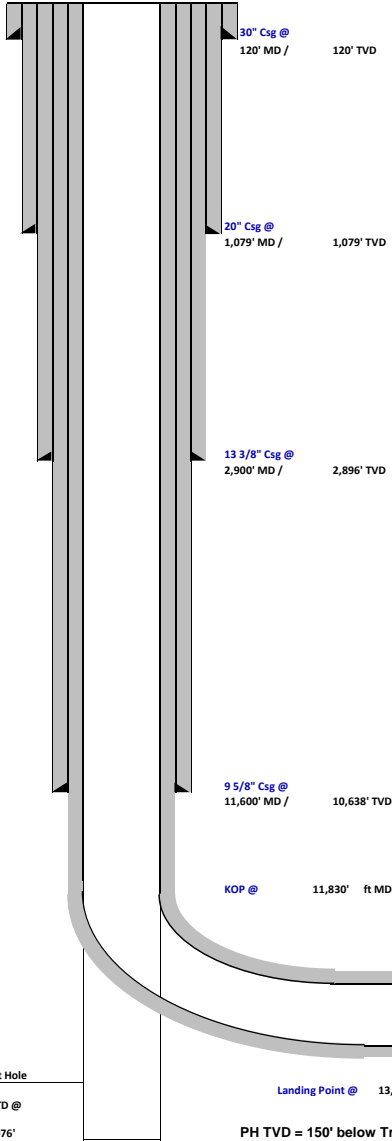

FORMATION TOPS	
Formation	Depth TVD
Deepest Fresh Water	1029'
Sewickley Coal	925'
Pittsburgh Coal	1023'
Big Lime	2,242'
Berea	2,860'
Tully	6,806'
Marcellus	6,919'
Onondaga	6,971'
Salina	7,694'
Lockport	8,703'
Utica	11,525'
Point Pleasant	11,793'
Landing Depth	11,843'
Trenton	11,926'
Pilot Hole TD	12,076'

CASING SUMMARY							
Type	Hole Size (in)	Csg Size (in)	Depth (MD)	Depth (TVD)	Weight (lb/ft)	Grade	Top of Cement
Conductor	36	30	120'	120'	8W	8W	Surface
Surface	26	20	1,079'	1,079'	106.5	J55	Surface
Intermediate 1	17 1/2	13 3/8	2,900'	2,896'	54.5	J55	Surface
Intermediate 2	12 1/4	9 5/8	11,600'	10,638'	47	HPP110	Surface
Production	8 1/2	5 1/2	22,323'	12,002'	23	HCP110	Surface

CEMENT SUMMARY				DRILLING DETAILS	
	Sacks	Class	Density	Fluid Type	Centralizer Notes
Conductor	338	A	15.6	Air	None
Surface	1,868	A	15.6	Air	3 Centralizers at equal distance
Intermediate 1	2,215	A	15	Air	1 Centralizer every other jt
Intermediate 2	3,097	A	14.5	Air	1 Centralizer every other jt
Production	4,673	A	15	Air / SOBM	1 every other joint in lateral; 1 per joint in curve; 1 every other jt to sfc

JZ 9/29/2020

Pilot Hole
 PH TD @ 12,076'
 PH TVD = 150' below Trenton Top
 Landing Point @ 13,265' MD / 11,843' TVD

Lateral TD @ 22,323' ft MD
 12,002' ft TVD



Tug Hill Operating, LLC Casing and Cement Program

Fitzgerald S-19HU

Casing

	String	Grade	Bit Size	Depth (Measured)	Cement Fill Up
Conductor	30"	BW	36"	120'	CTS
Surface	20"	J55	26"	1,079'	CTS
Intermediate 1	13 3/8"	J55	17 1/2"	2,900'	CTS
Intermediate 2	9 5/8"	HPP110	12 1/4"	11,600'	CTS
Production	5 1/2"	HCP110	8 1/2"	22,323'	CTS

Cement

Surface: Premium NE-1 + 2% bwoc CaC12 + 46.5% Fresh Water – Surface Cement mixed at 15.6 ppg, Y=1.2

Intermediate 1: Premium NE-1 + 1% bwoc CaC12 + 46.5% Fresh Water – Intermediate Cement mixed at 15.6 ppg, Y=1.2

Intermediate 2: Premium NE-1 + 1% bwoc CaC12 + 46.5% Fresh Water – Intermediate Cement mixed at 15.6 ppg, Y=1.99

Production: 50:50 Poz: Premium NE-1 + .1% bwoc ASA-301 + 60lb/sk ASCA-1 + .35% bwoc BA-10A + .25% bwoc MPA-170, 44 lb sack + .5% bwoc R-3 + .75 gals/100sk FP-13L – Production Cement mixed at 15.2ppg, Y = 1.18